

Espace Immobilier Lyonnais



Cahier des charges pour le remplacement des
menuiseries de la Perralière

Juillet 2016



Nous faisons **grandir** vos projets

Description des travaux

- Remplacement des menuiseries bois simple vitrages en façades et pignons des bâtiments.
- Rénovation par des menuiseries PVC double vitrage 4/16/4 argon de couleur blanche dont les caractéristiques techniques sont les suivantes :
 - Uw < 1.4 W/m².K.
 - Ug < 1.1 W/m².K.
 - Sg = 0.5 (+/- 0.05)
 - TI > 70
- Panneaux remplissage portes : U > 1.20 W/m².K.
- Respect de l'aspect général des menuiseries (petite et grande porte pleine/ parties vitrées fixes et traverses intermédiaires) au plus proche des dimensions d'origines, en particulier pour les largeurs de passage des portes :
 - Grande porte > 780 mm de passage
 - Petite porte > 160 mm de passage
- Cf. plans des menuiseries existantes en annexe.

- Les portes pleines auront un aspect extérieur et intérieur le plus lisse possible (profondeur du panneau < 7mm par rapport aux montants PVC du châssis)
- Installation -en option- de volets roulants extérieurs (couleur blanc pour l'ensemble caisson/tablier/rails).
- Isolation des coffres de volets roulants intérieurs existants (dépose du mécanisme intérieur / mise en place d'une isolation R > 2.0 m².K/W + renforcement de l'étanchéité à l'air)



Me-1-g

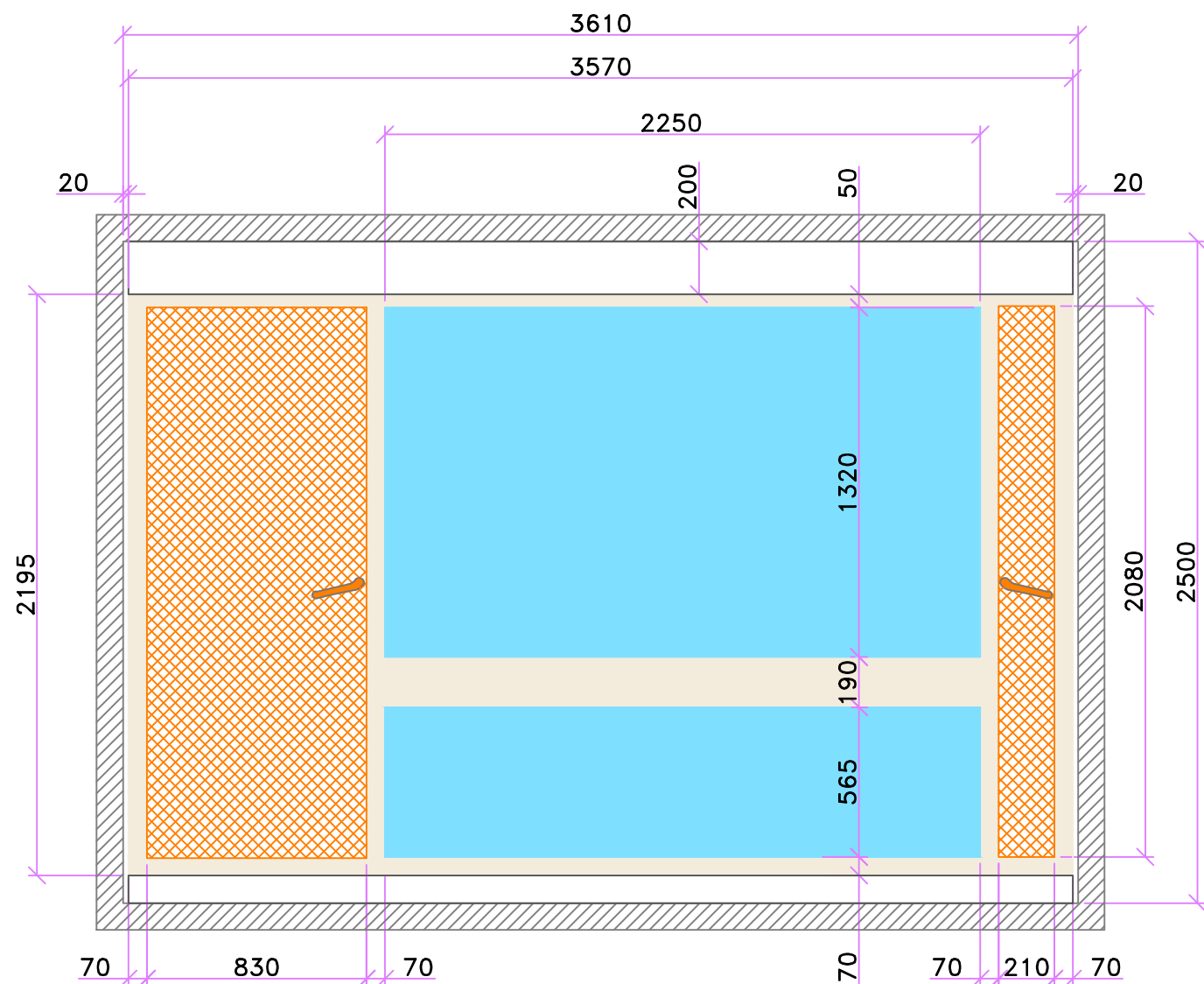

Me-1-d

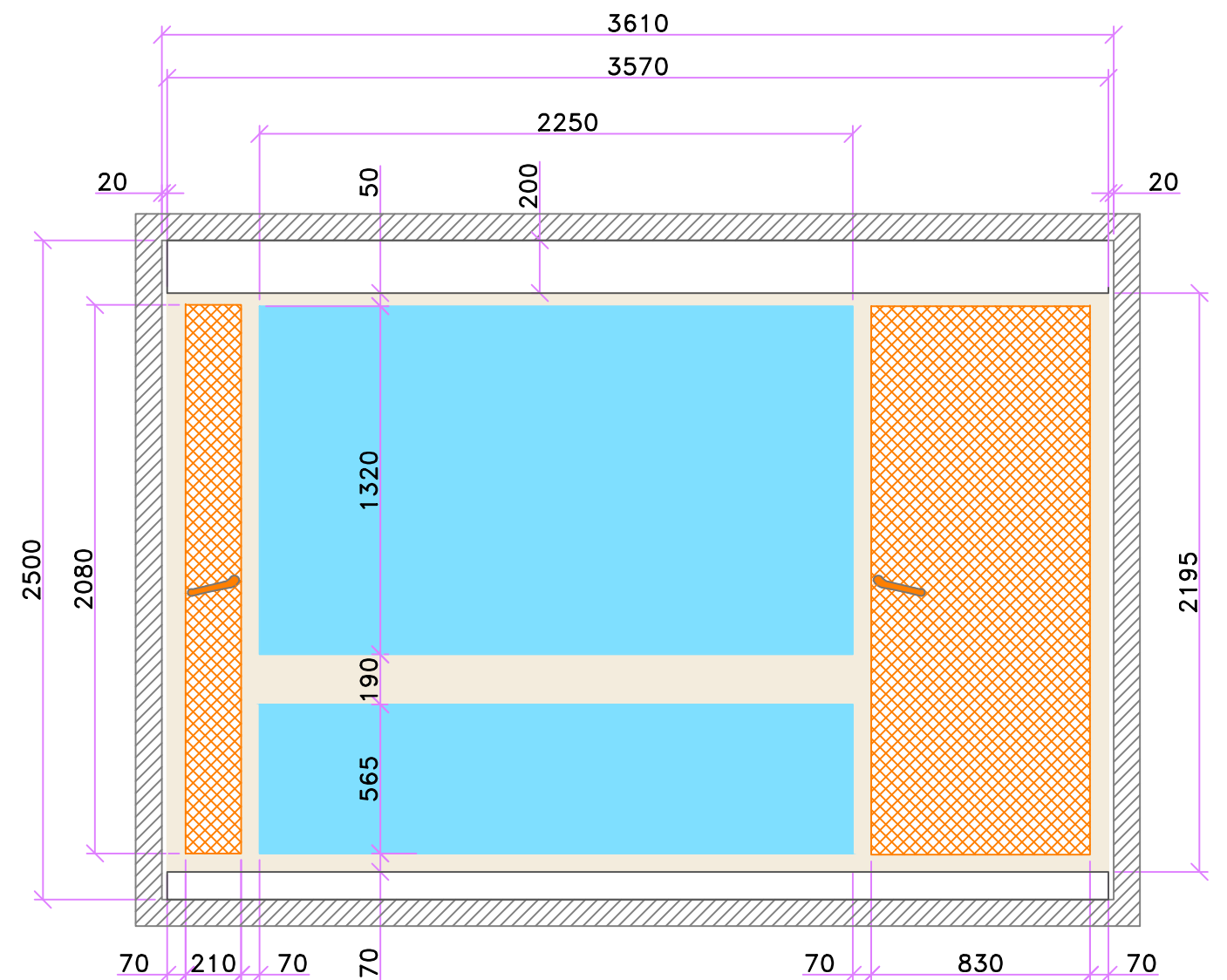

Me-2-g

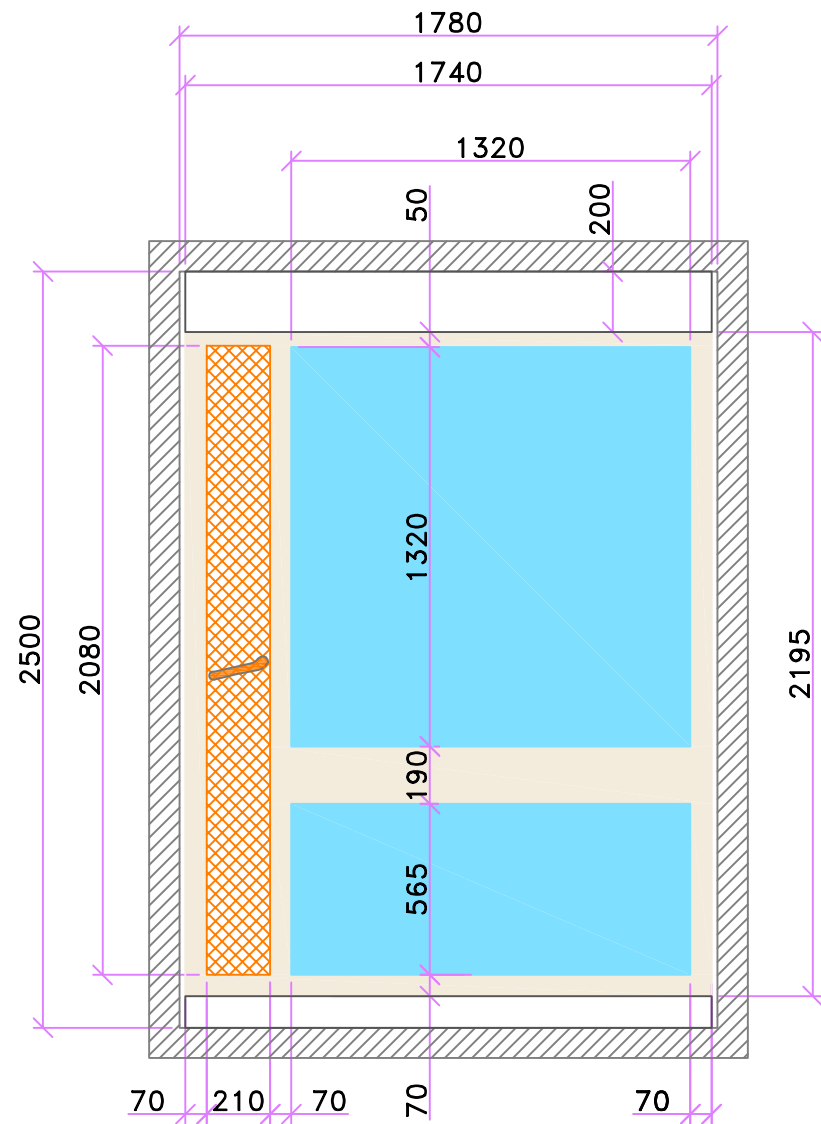

Me-2-d

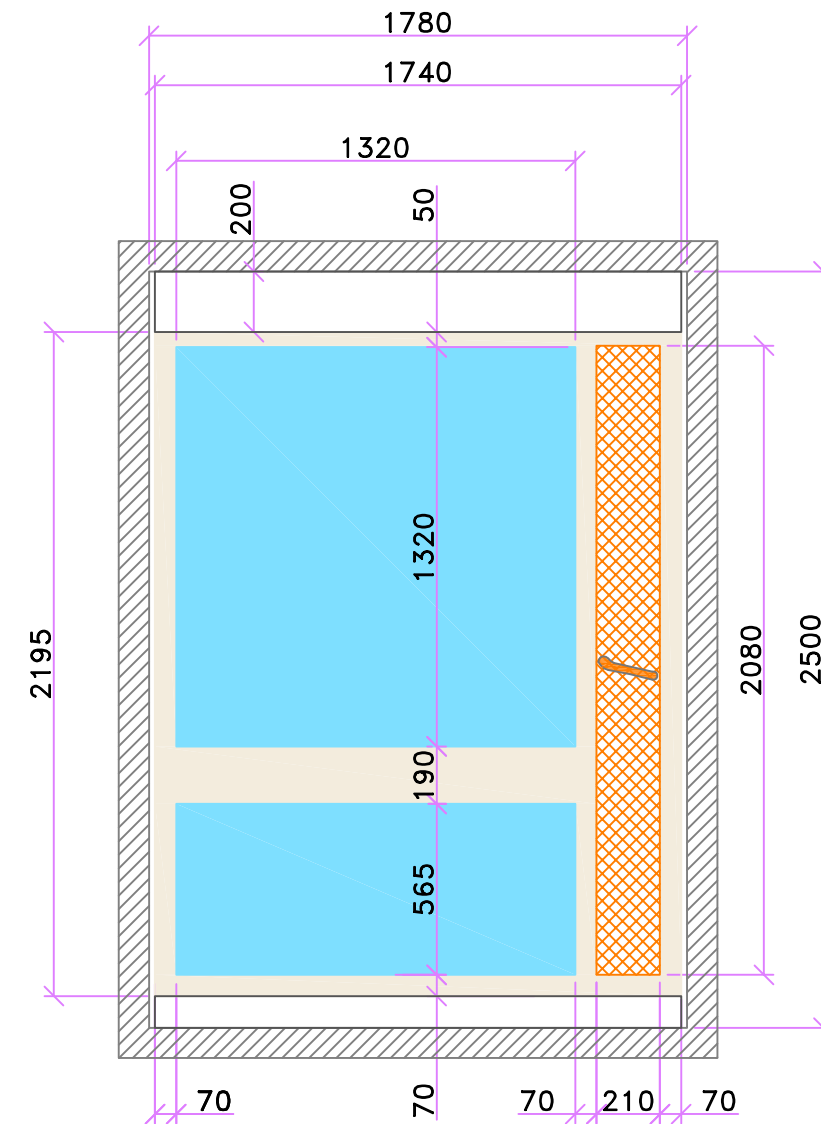

Me-3-g

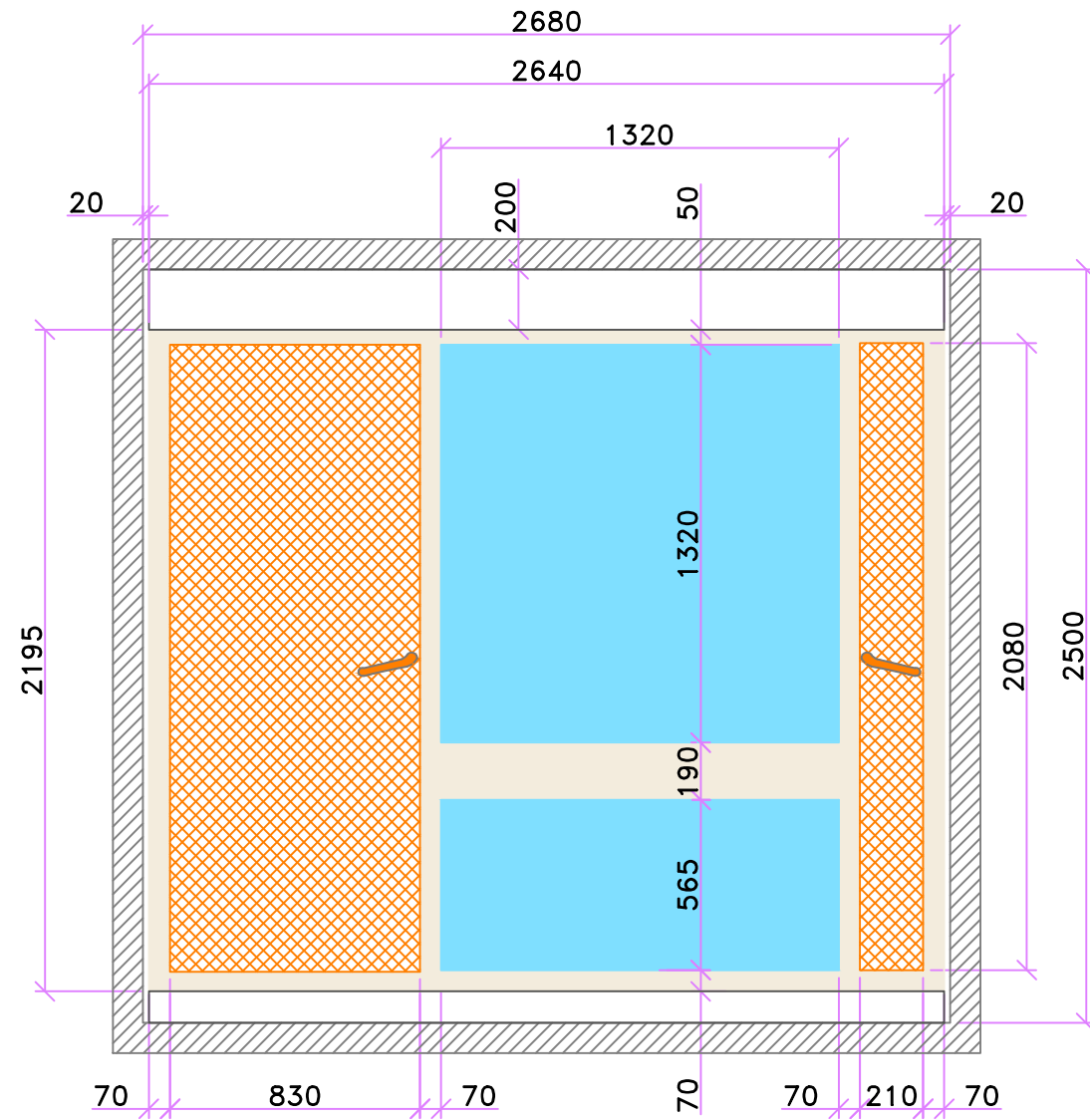

Me-3-d

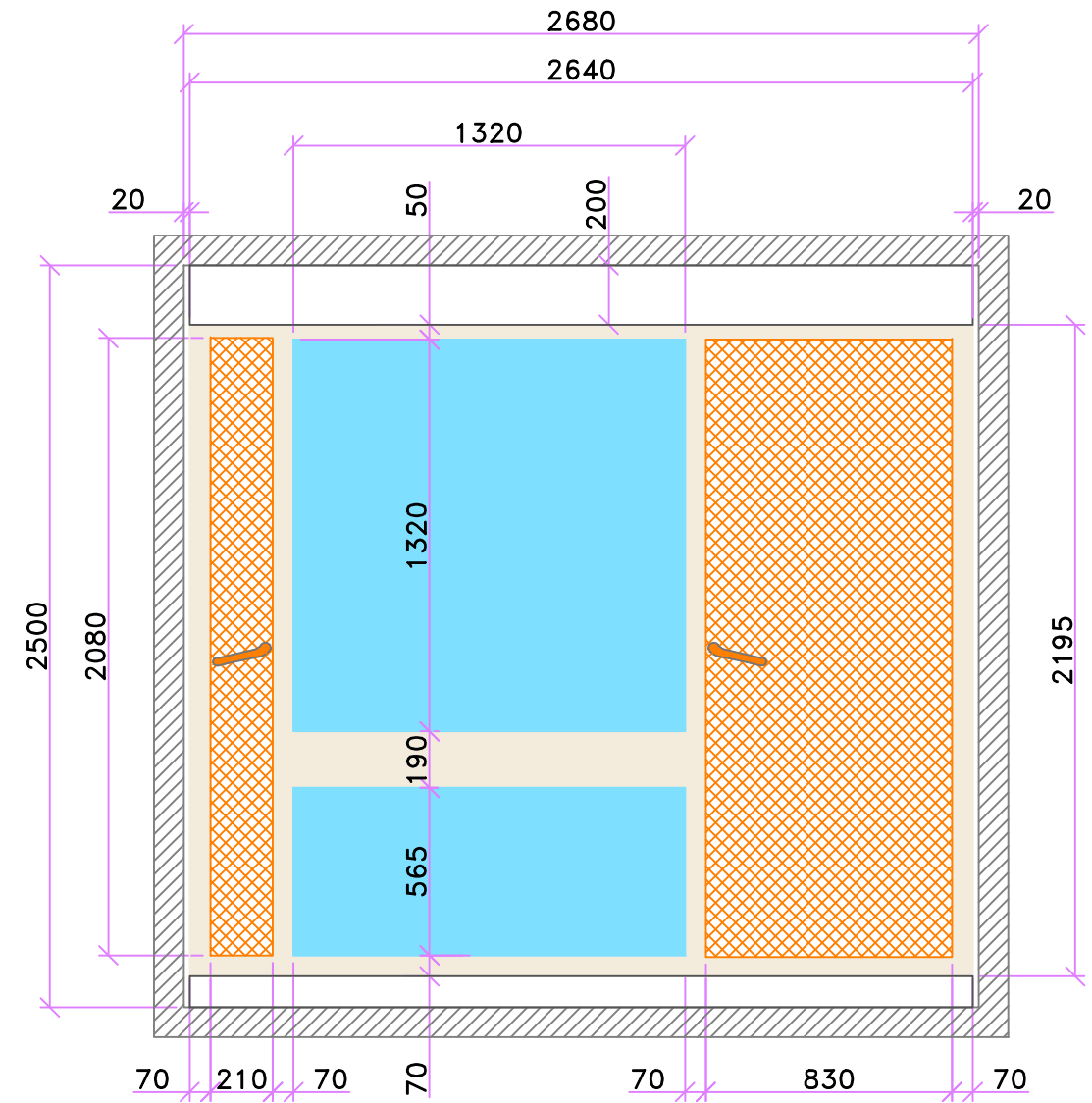

Me-4-g

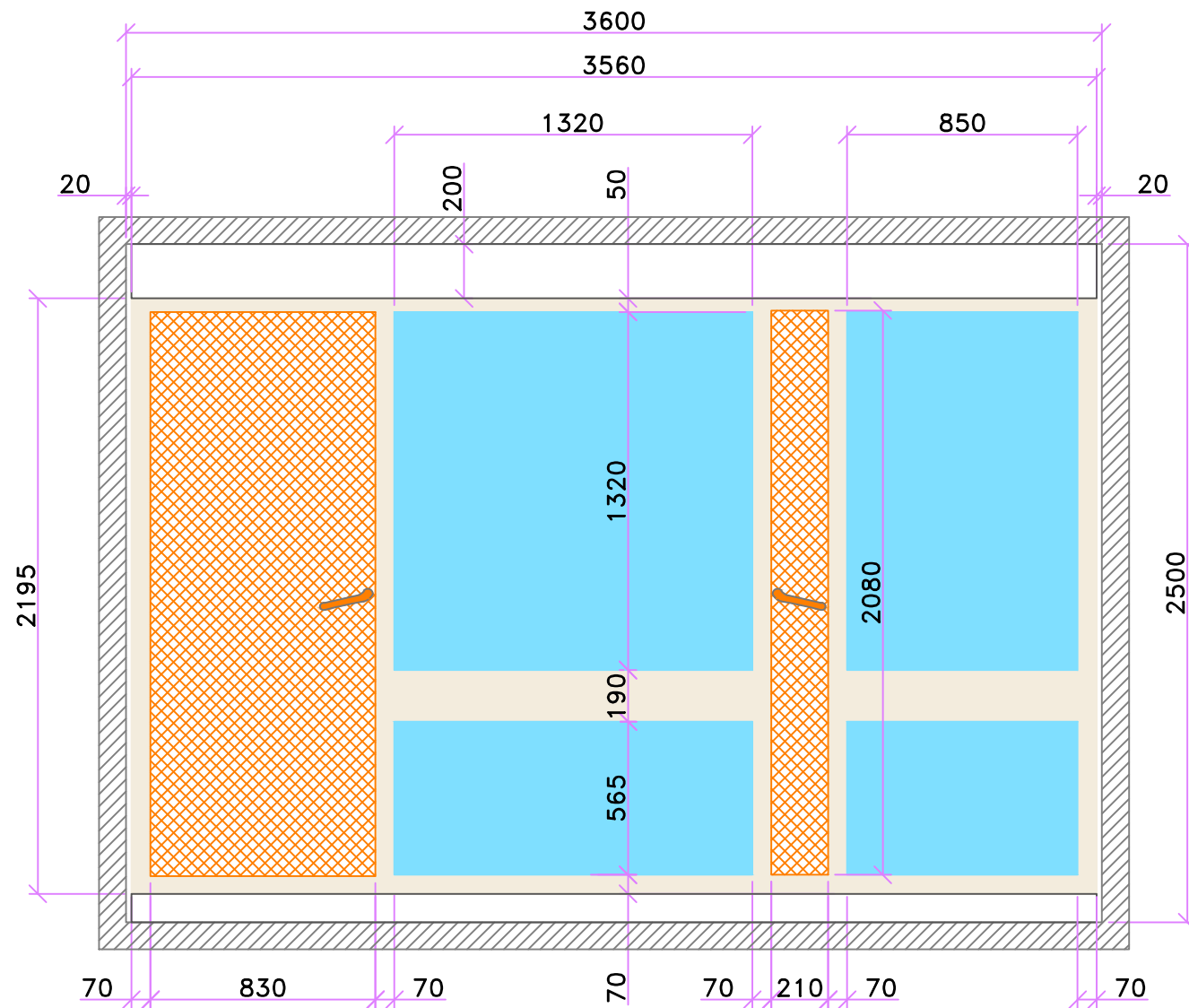

Me-4-d

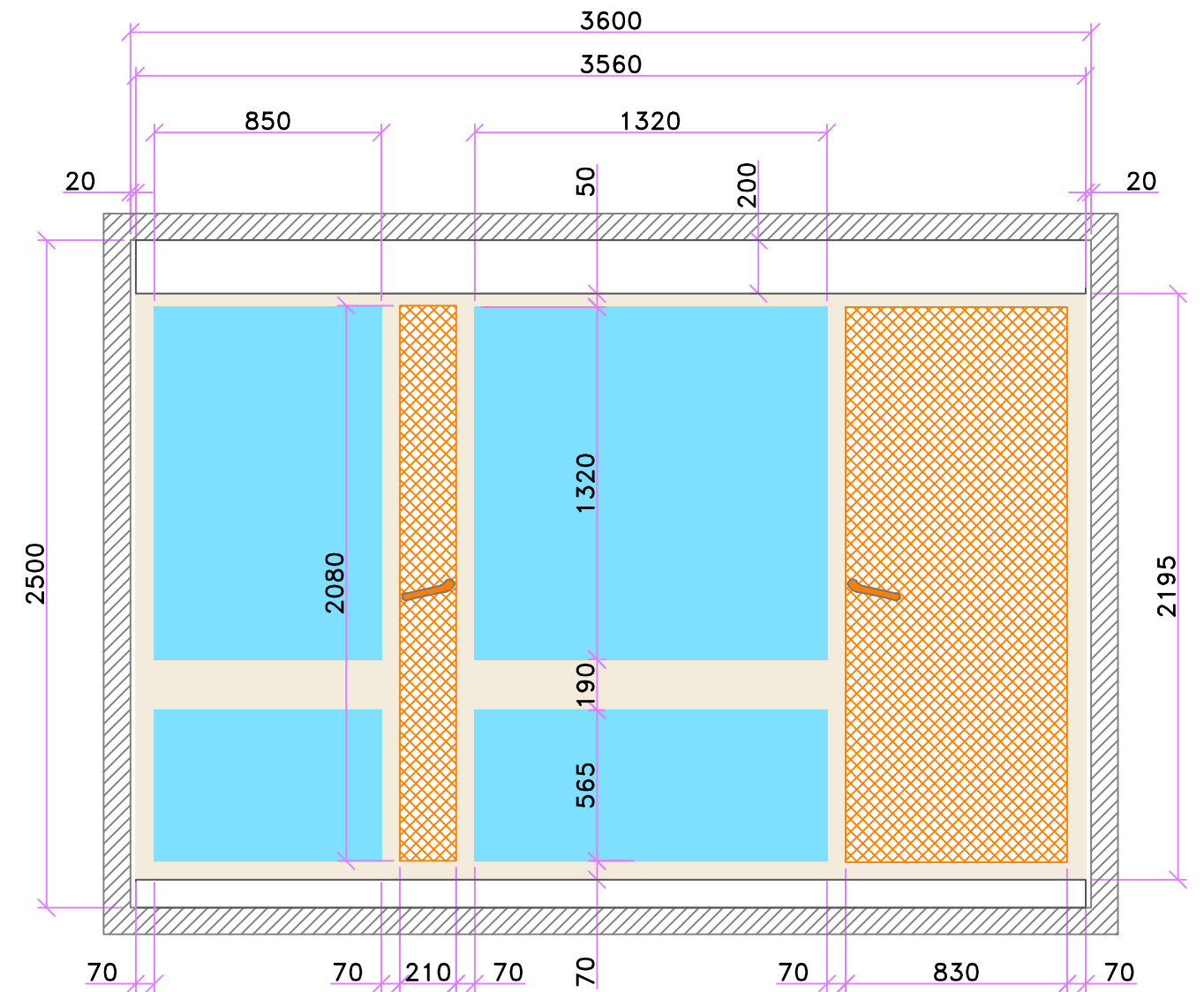

EIL-CPE
Résidence SP Perralière Villeurbanne



N°affaire: A20862
Phase: DCE
Indice: 1
Date: 10/09/2014
Ech - Format: 1/25 - A3
Dessinateur: ABENT

Me-4
ETAGE COURANT
IZOARD/LAUTARET/OISANS/ARCHES/MADELEINE/GALIBIER

Me-5-g

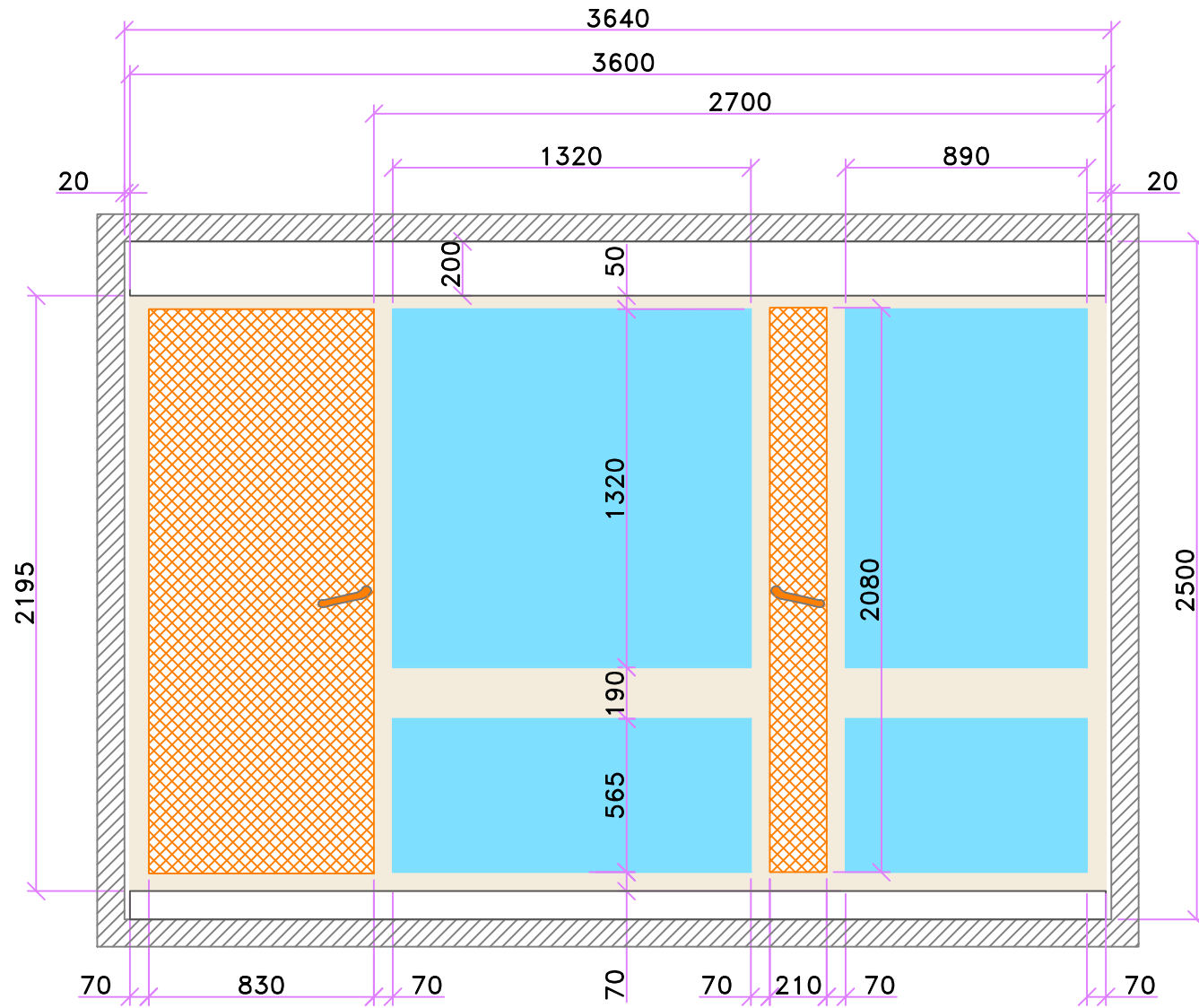

Me-5-d

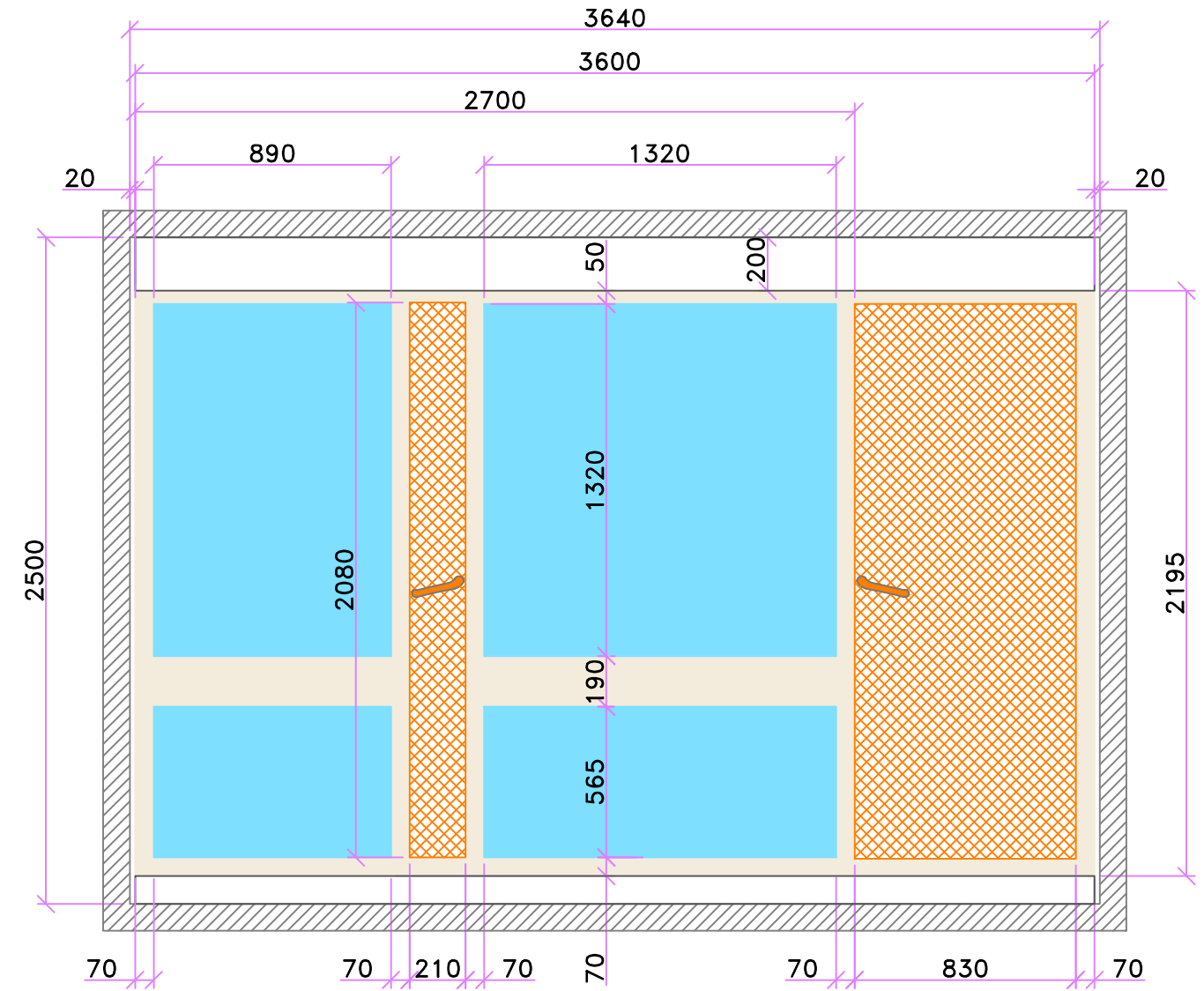

EIL-CPE
Résidence SP Perralière Villeurbanne



N°affaire: A20862
Phase: DCE
Indice: 1
Date: 10/09/2014
Ech - Format: 1/25 - A3
Dessinateur: ABENT

Me-5
ETAGE COURANT
IZOARD/LAUTARET/OISANS/ARCHES/MADELEINE/GALIBIER

Me-6-g

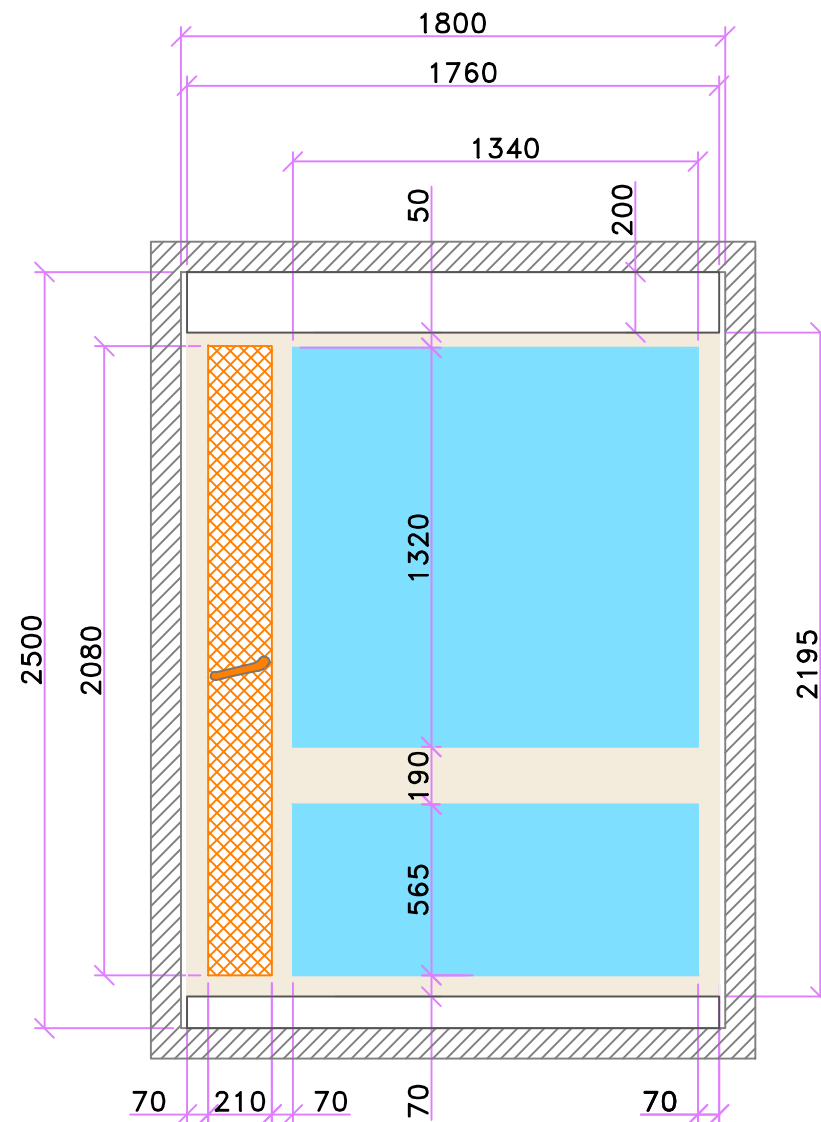

Me-6-d

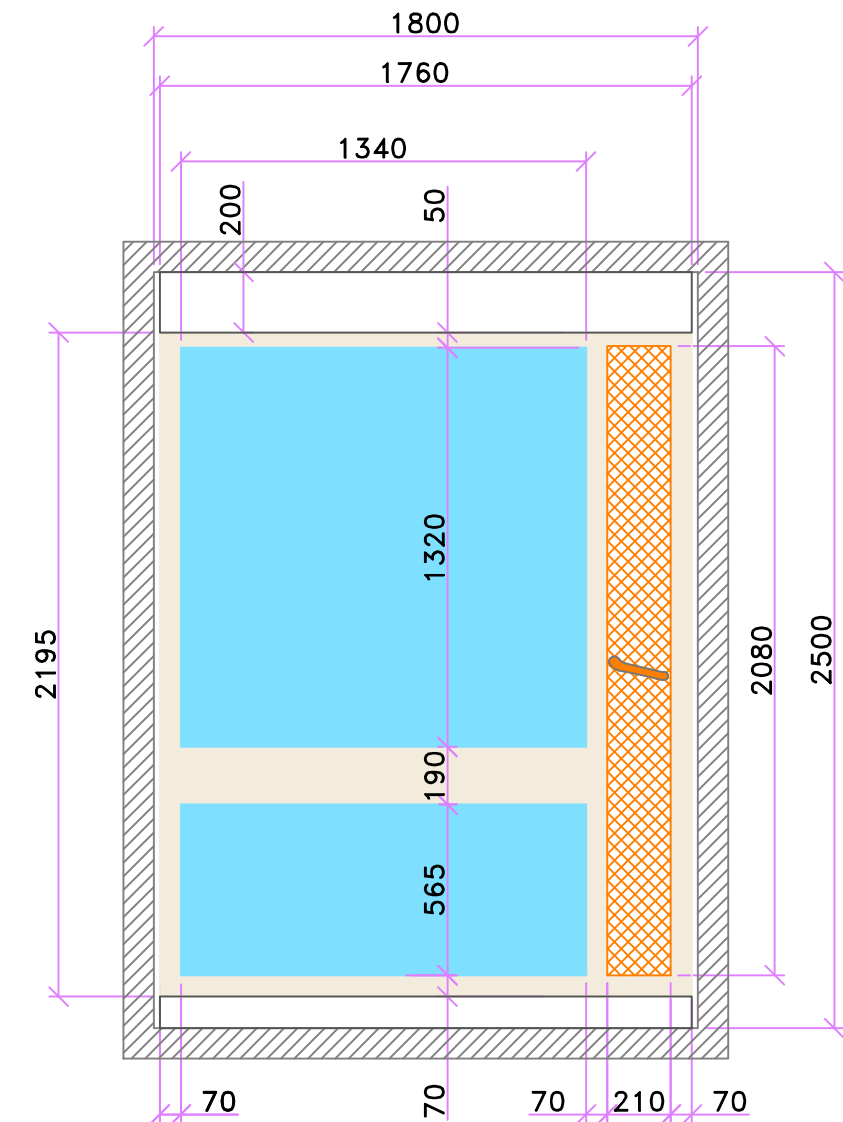

Mi-10-g

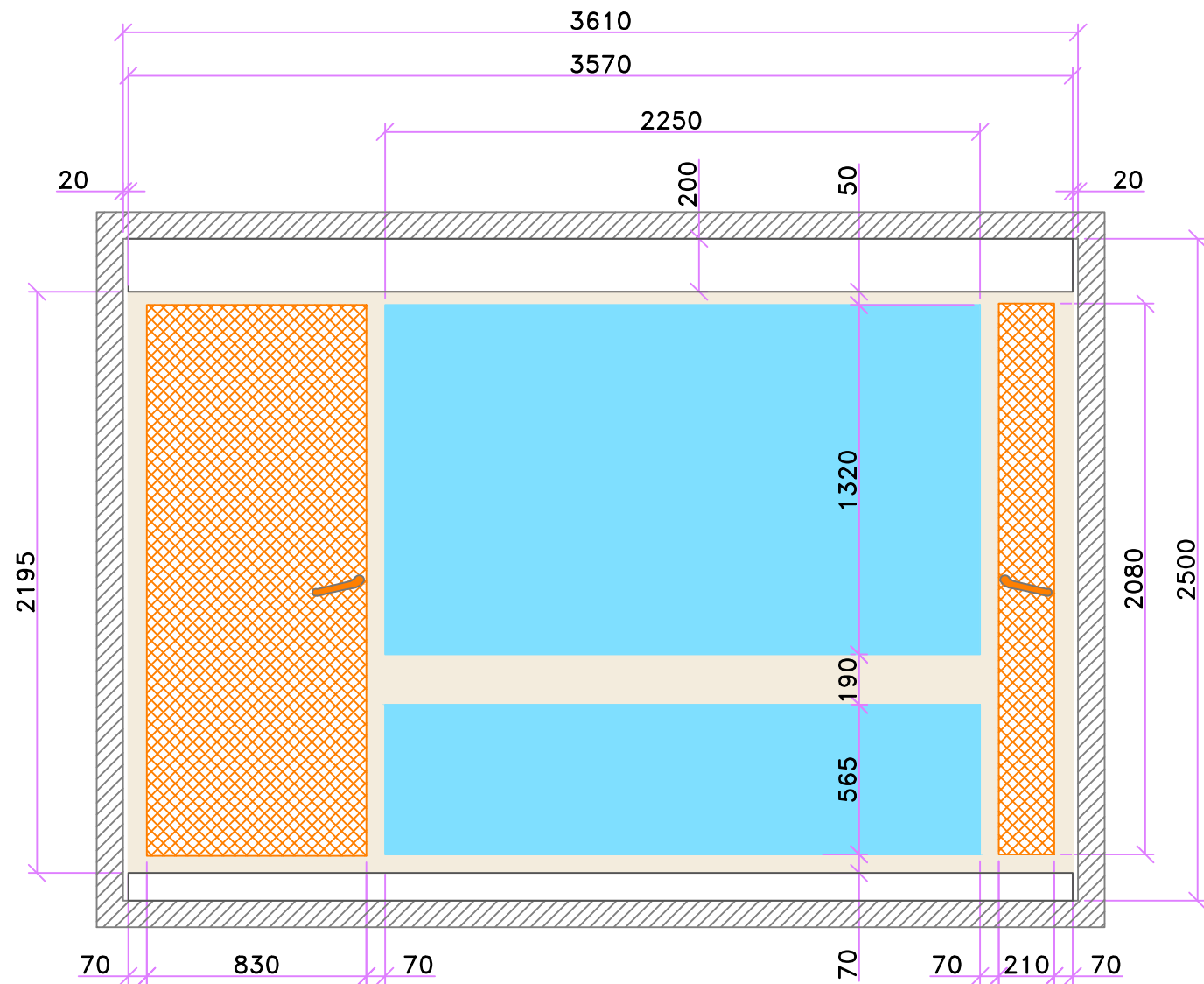

Mi-10-d

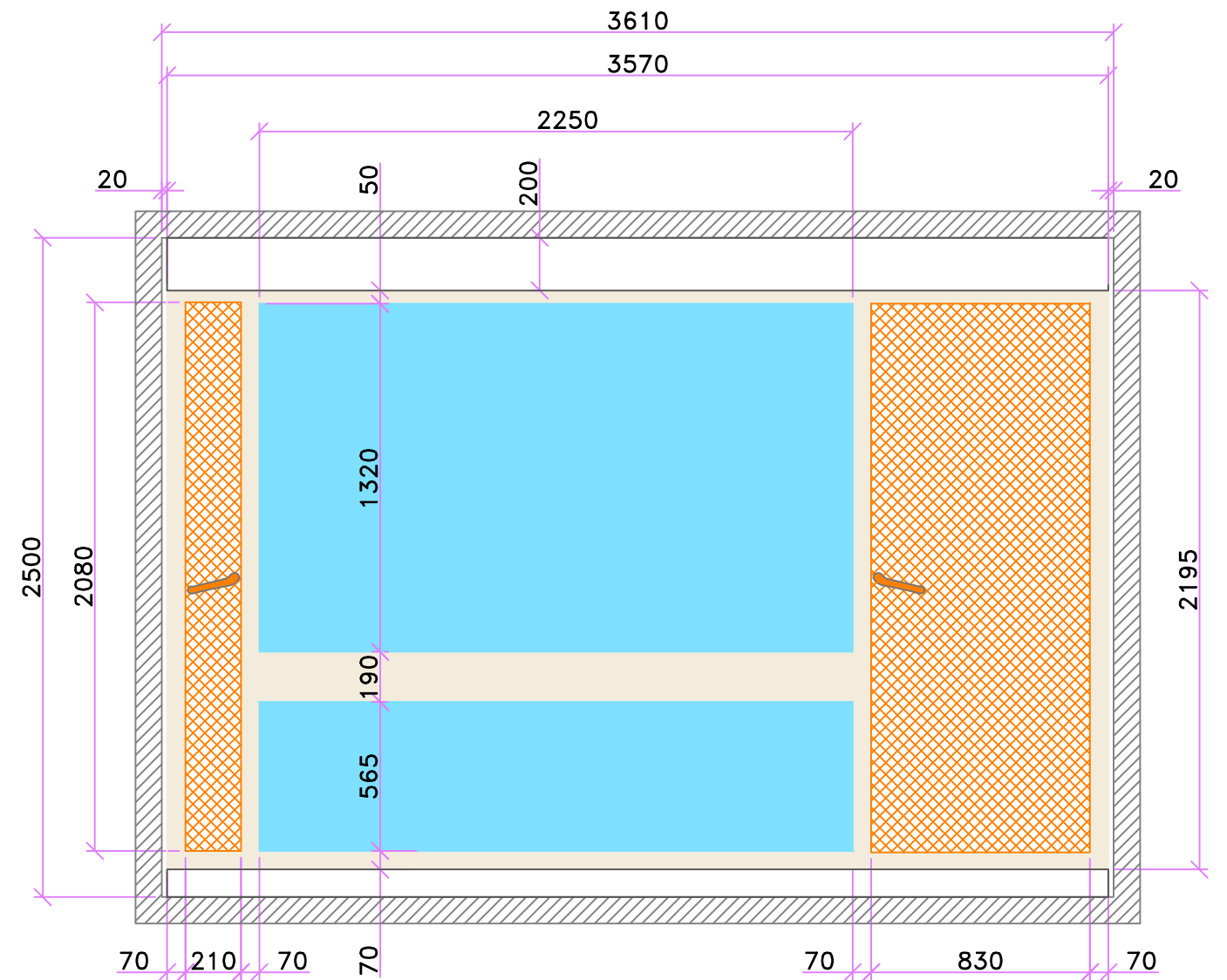

Mi-11-g

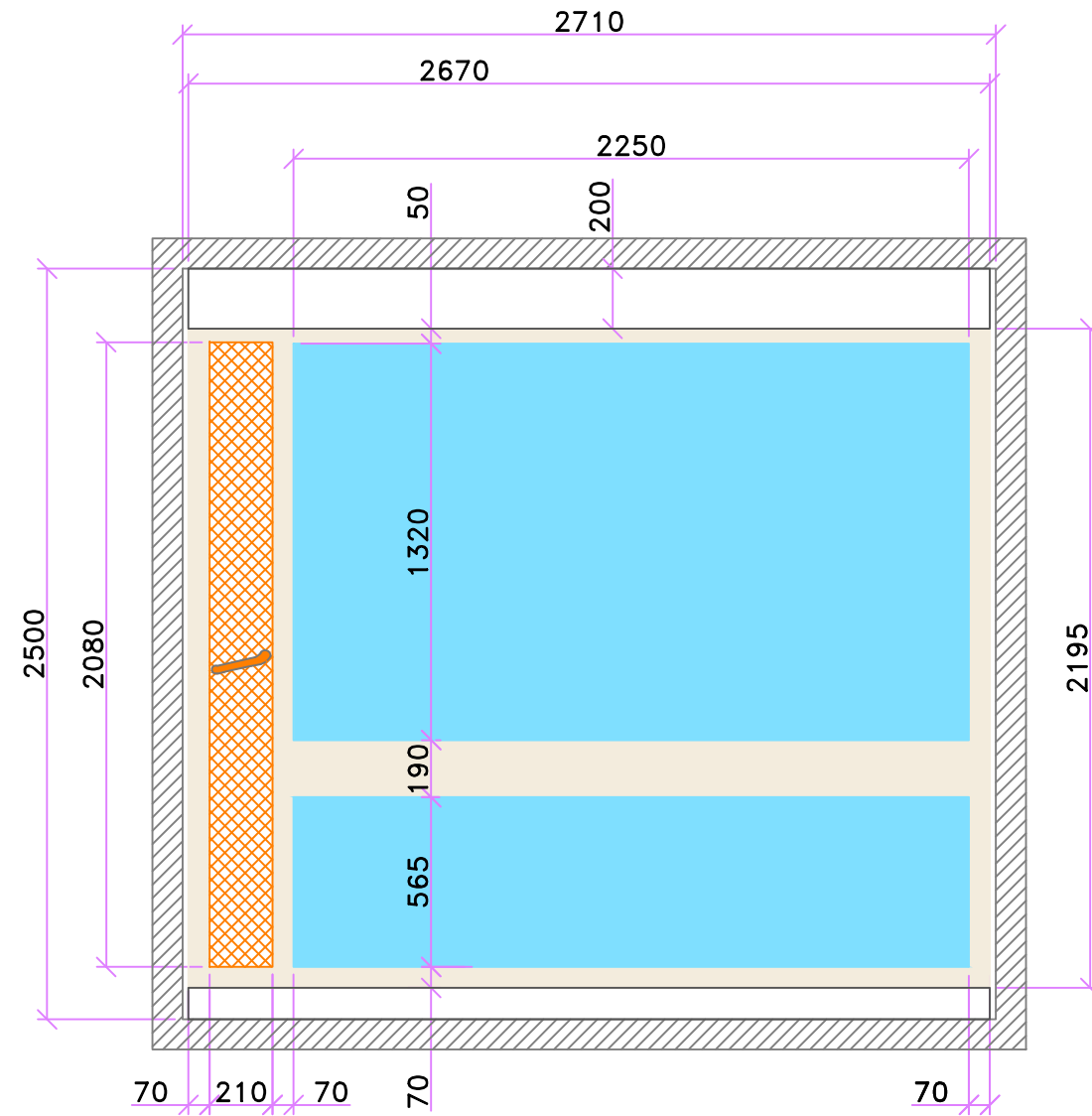

Mi-11-d

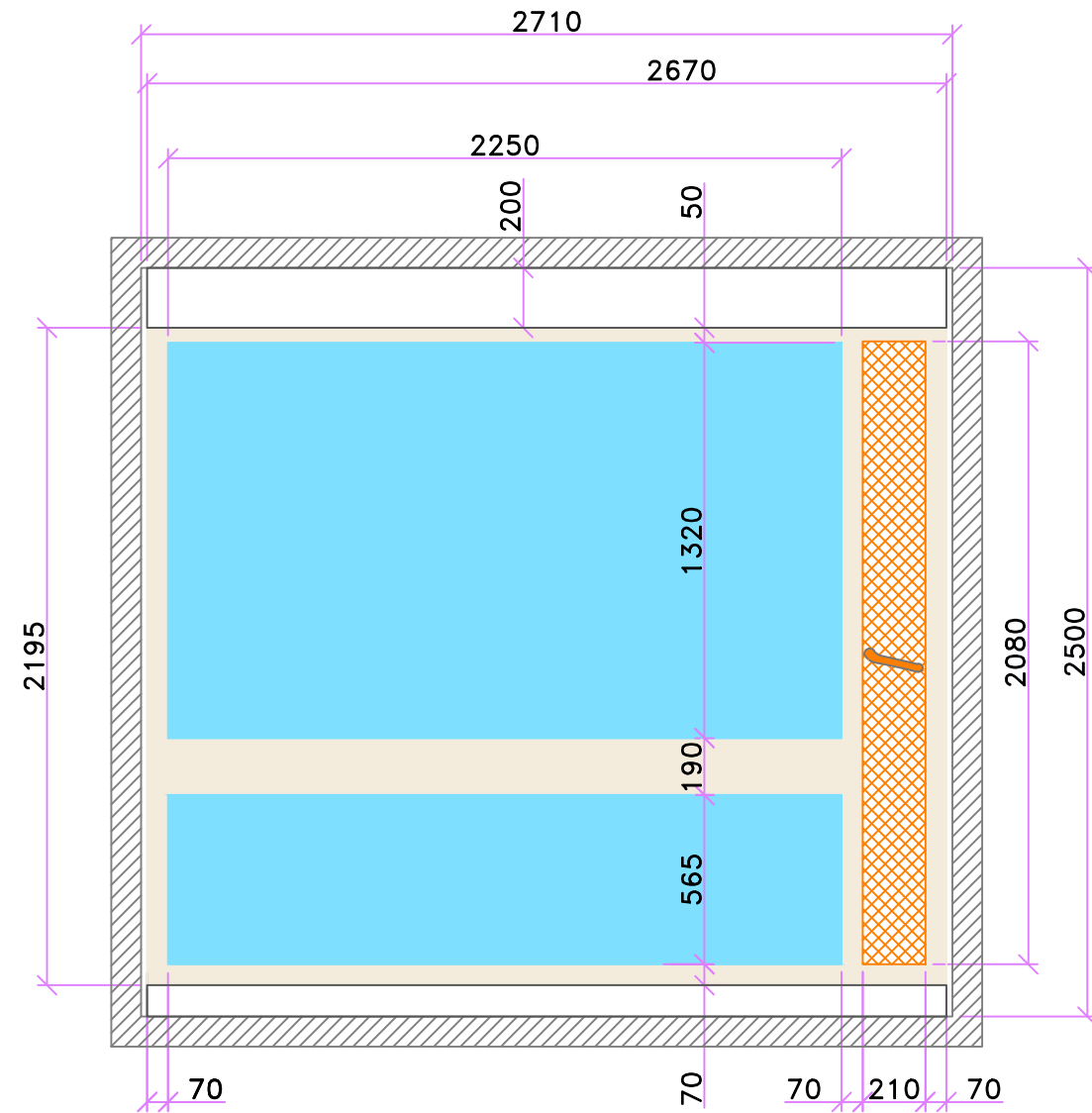

Mi-12-g

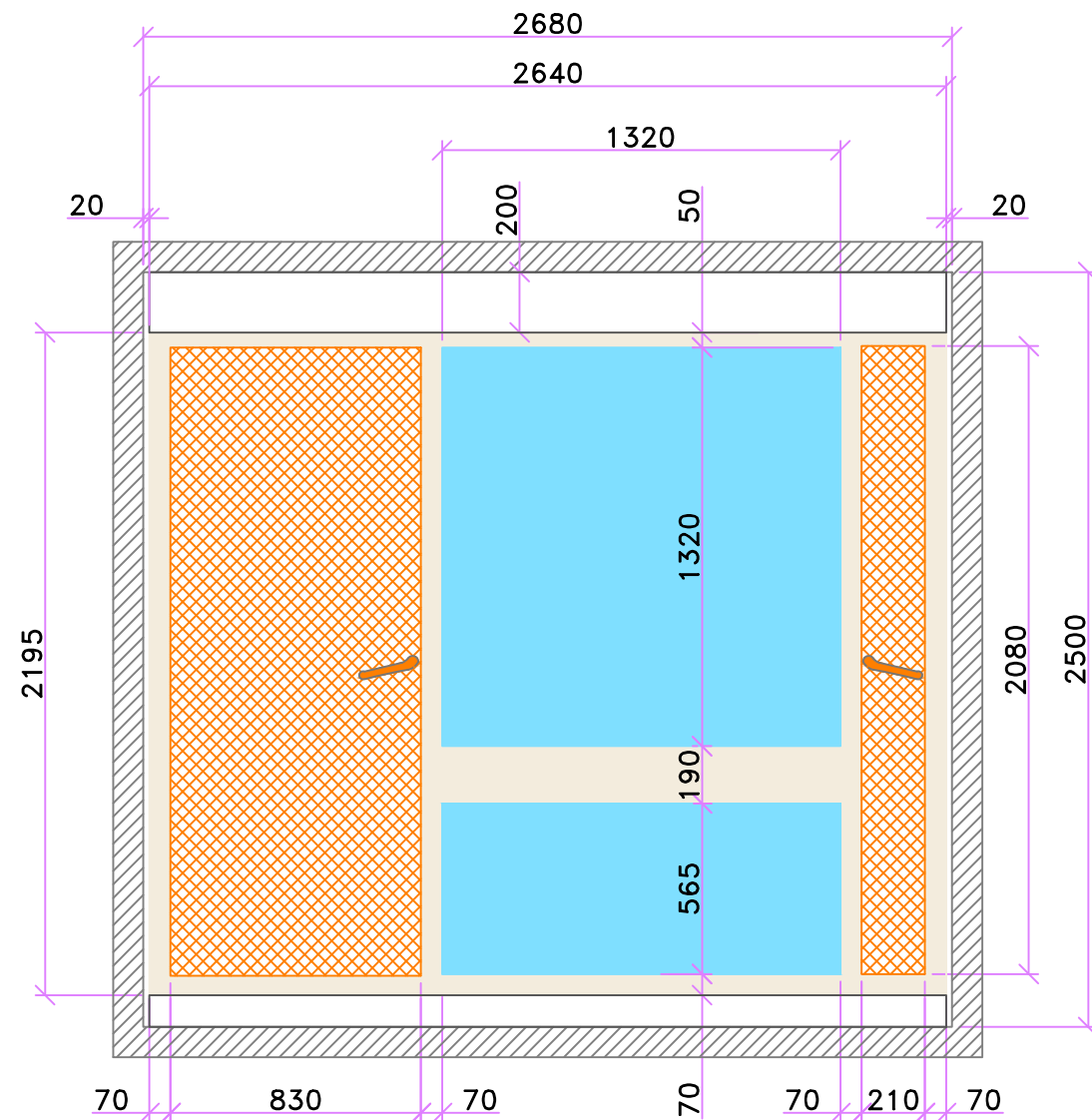

Mi-12-d

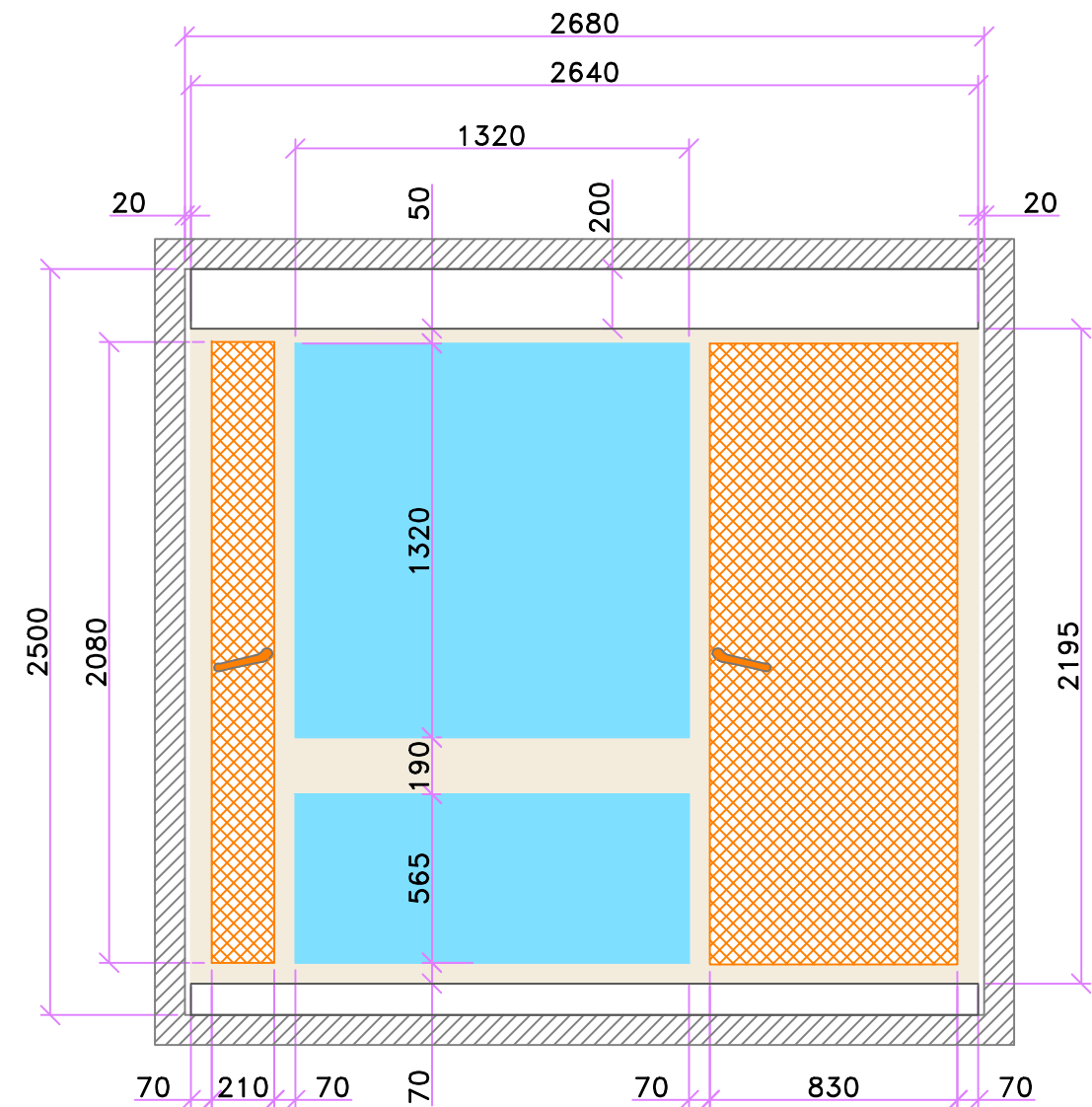

Mi-13-g

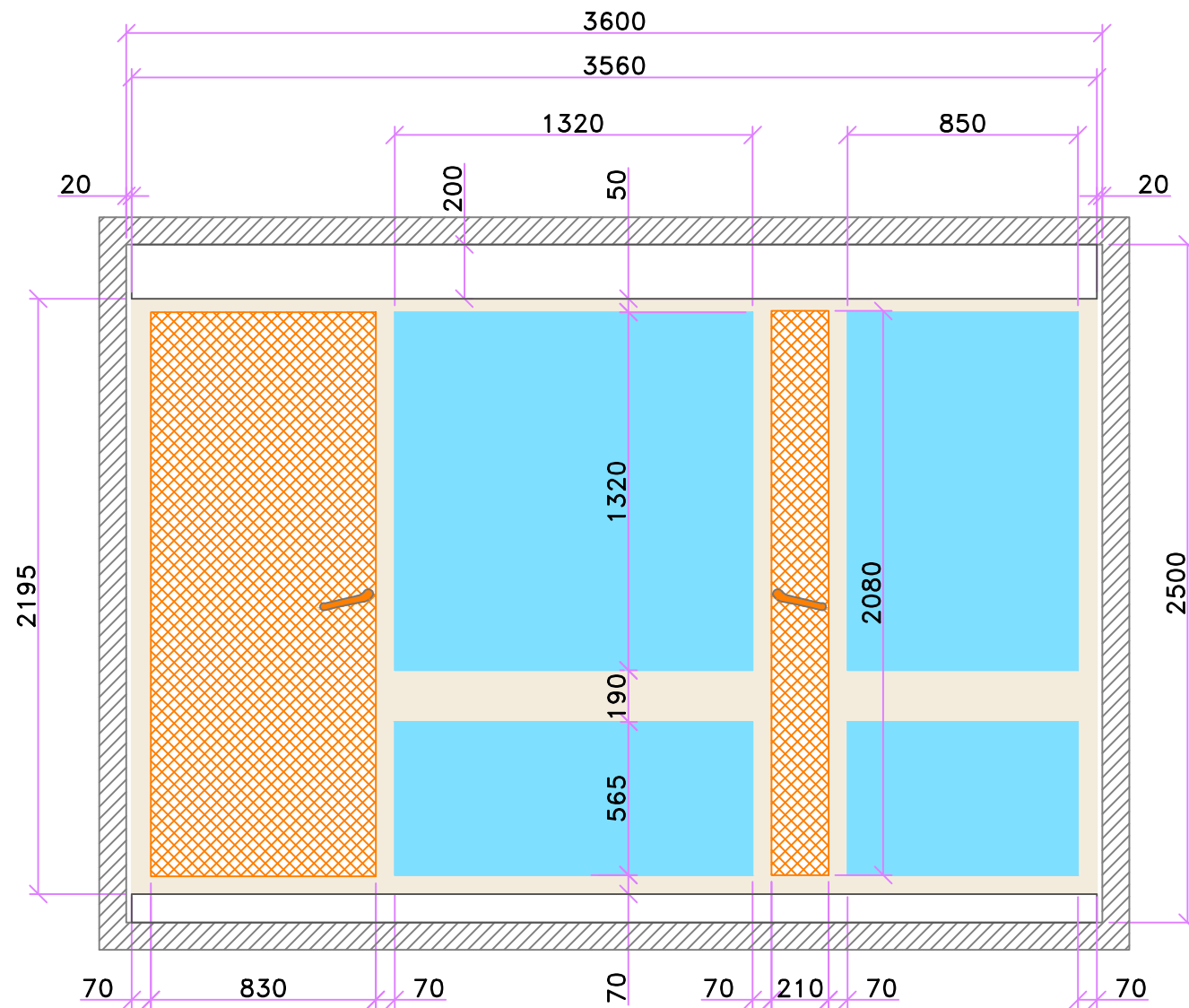

Mi-13-d

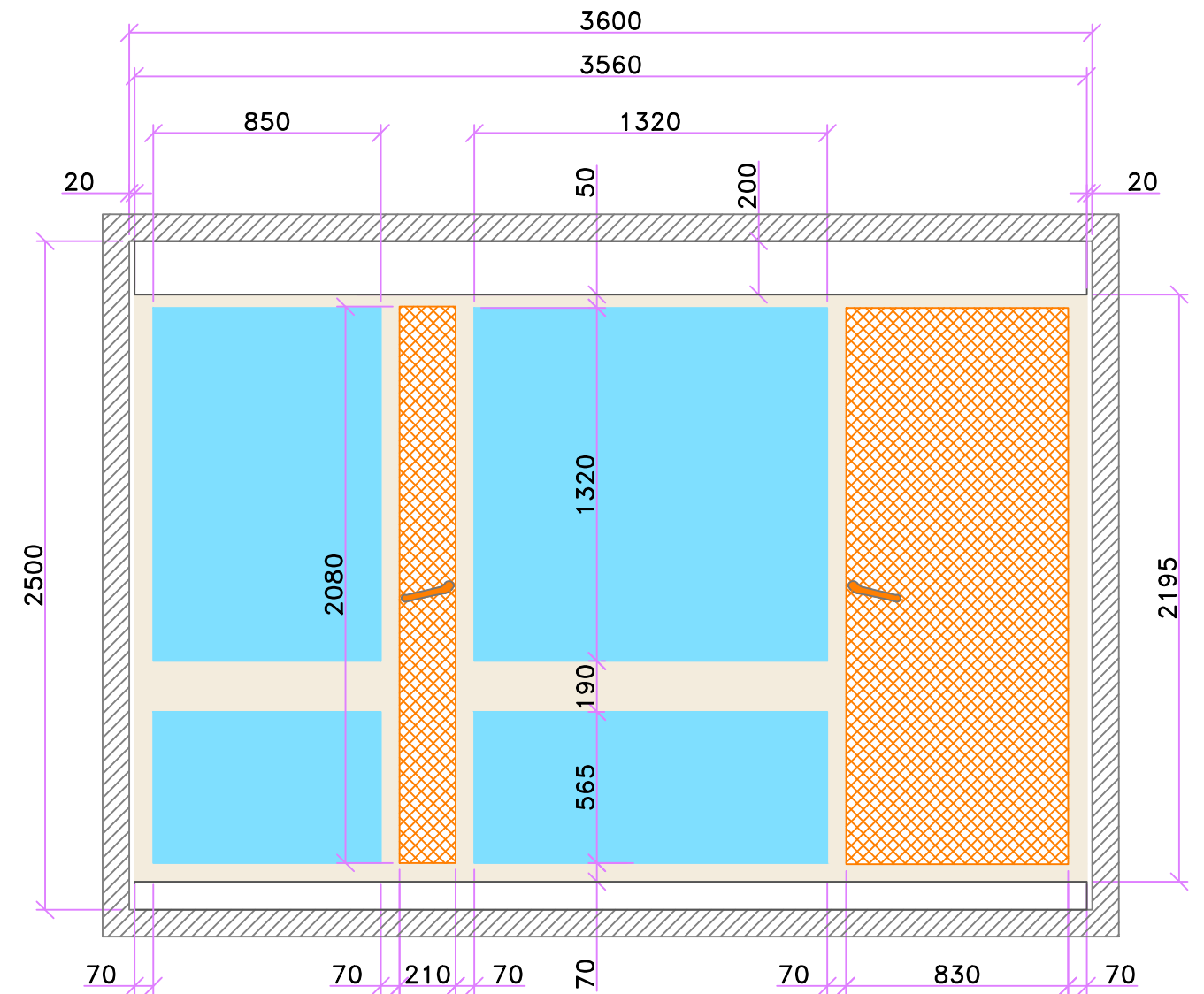

Mi-14-g

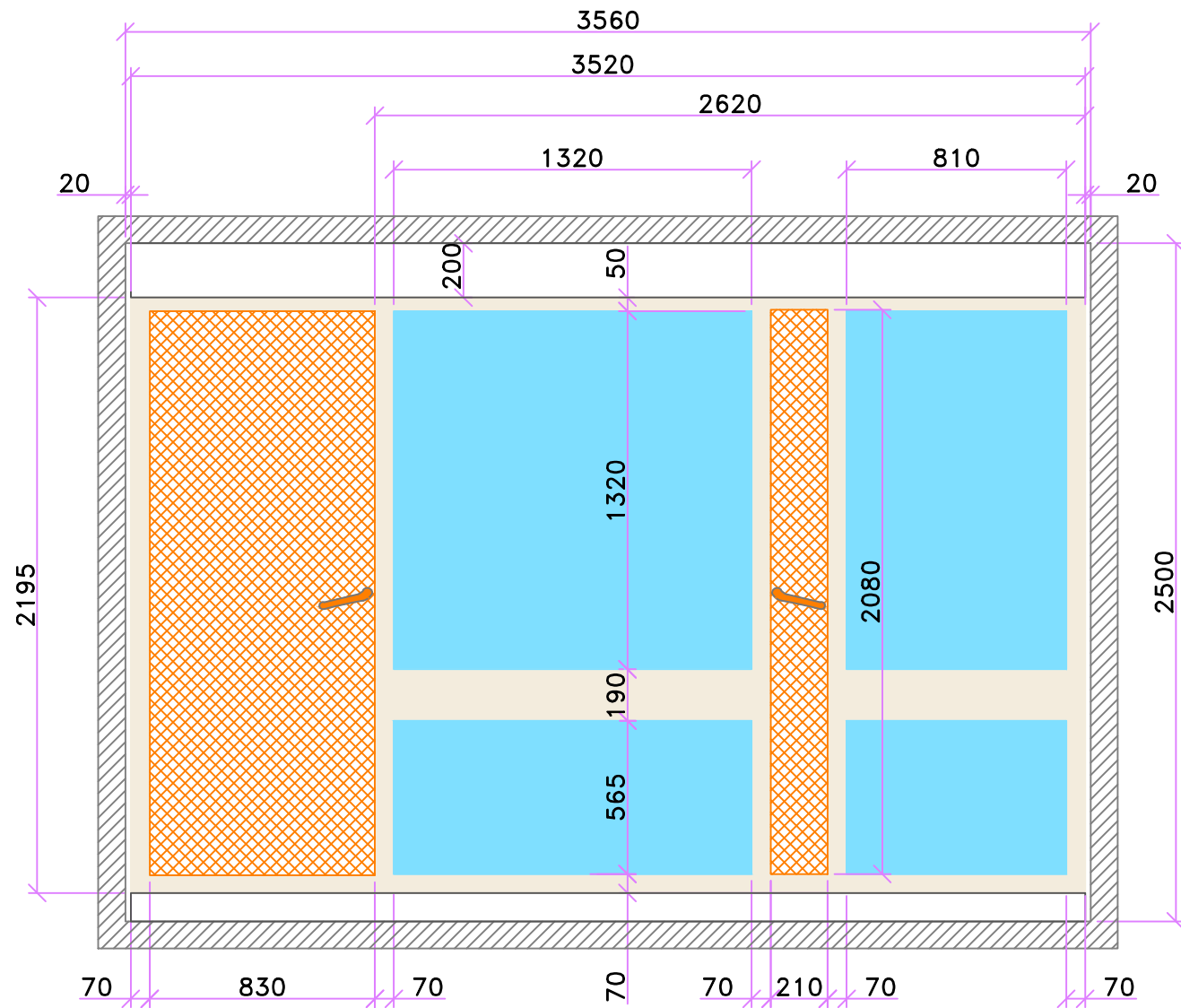

Mi-14-g

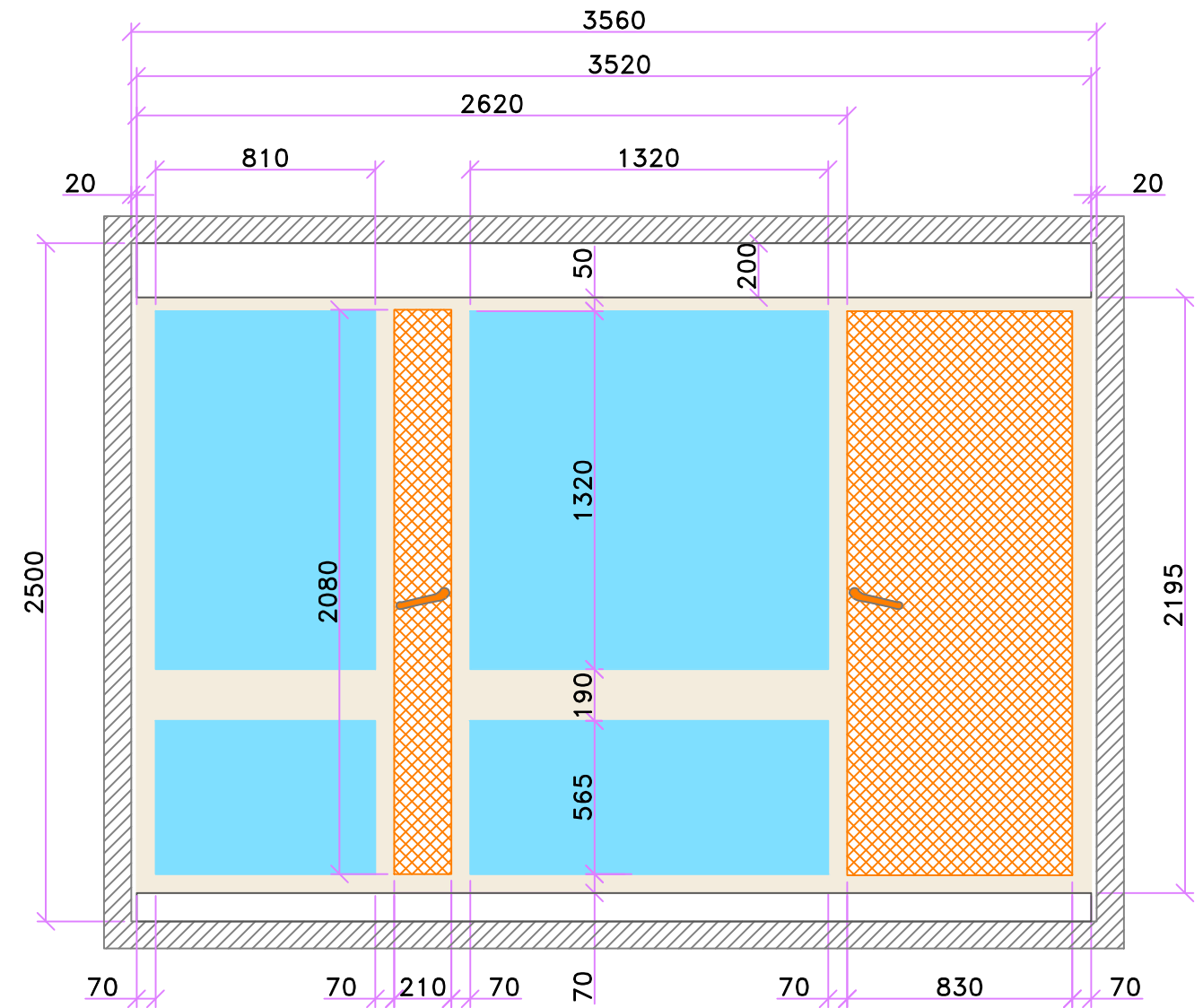

EIL-CPE
Résidence SP Perralière Villeurbanne



N°affaire: A20862
Phase: DCE
Indice: 1
Date: 10/09/2014
Ech - Format: 1/25 - A3
Dessinateur: ABENT

Mi-14
RDC
IZOARD/LAUTARET/OISANS/ARCHES/MADELEINE/GALIBIER

Mi-15-g

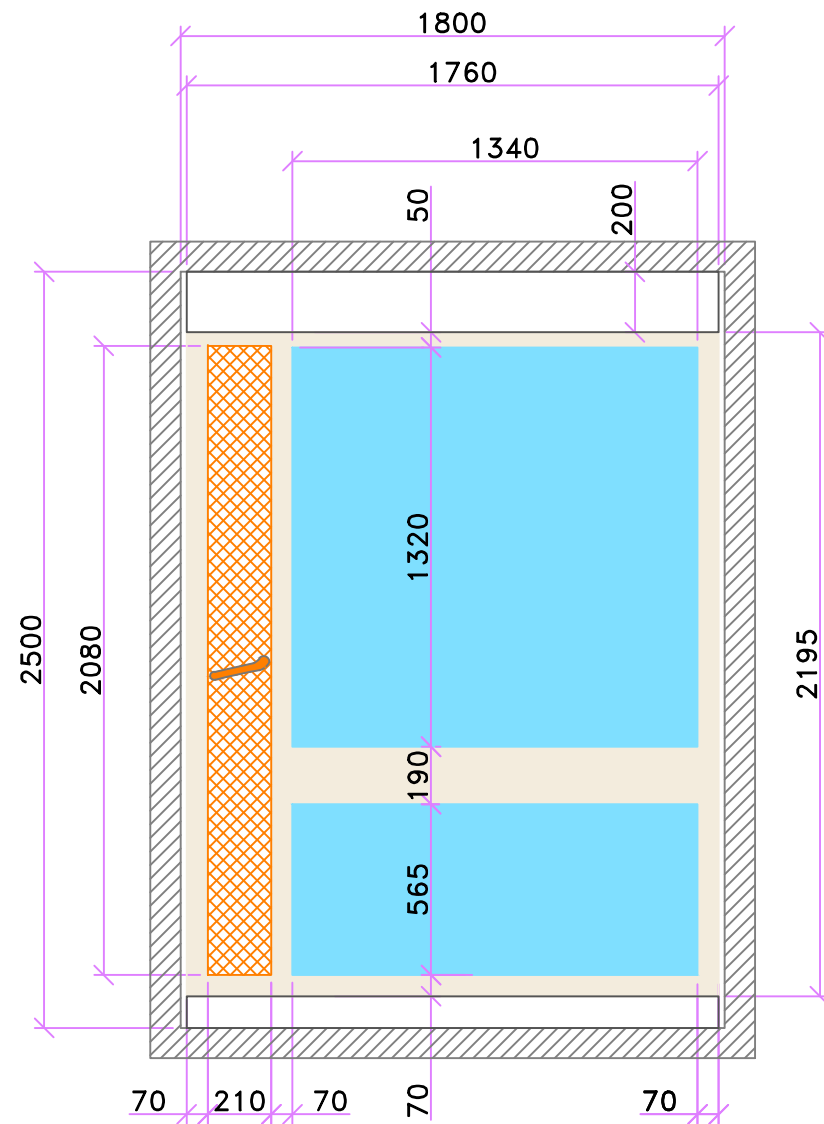

Mi-15-d

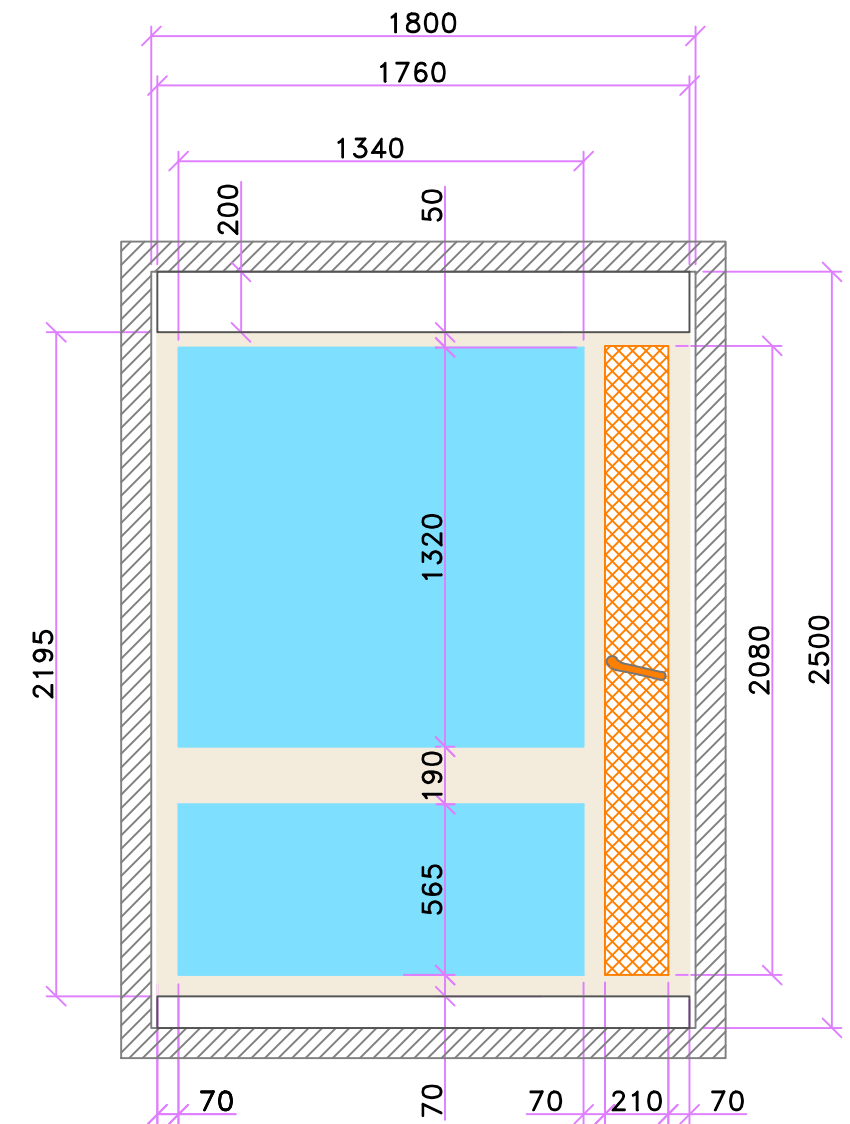

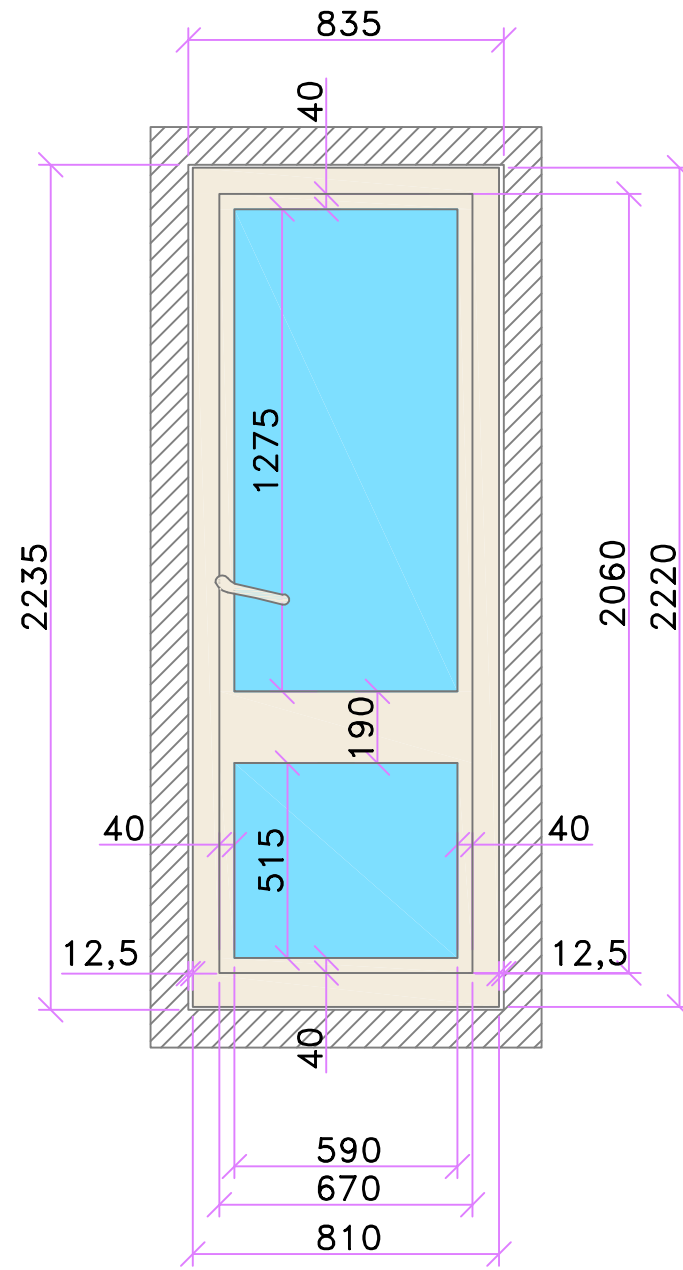

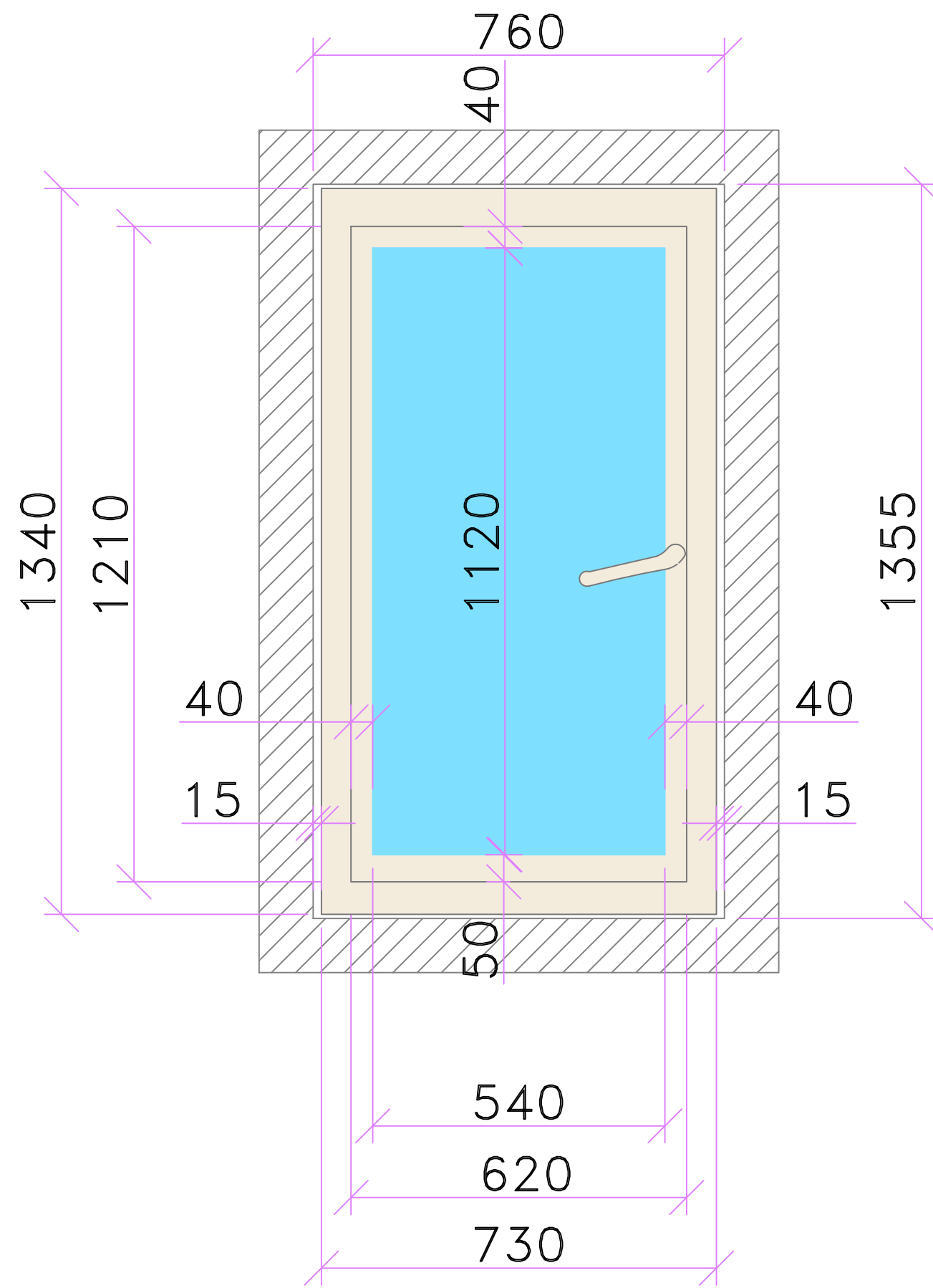

EIL-CPE
 Résidence SP Perralière Villeurbanne



N°affaire: A20862
 Phase: DCE
 Indice: 1
 Date: 10/09/2014
 Ech - Format: 1/10 - A3
 Dessinateur: ABENT

Fe-1
 PIGNONS

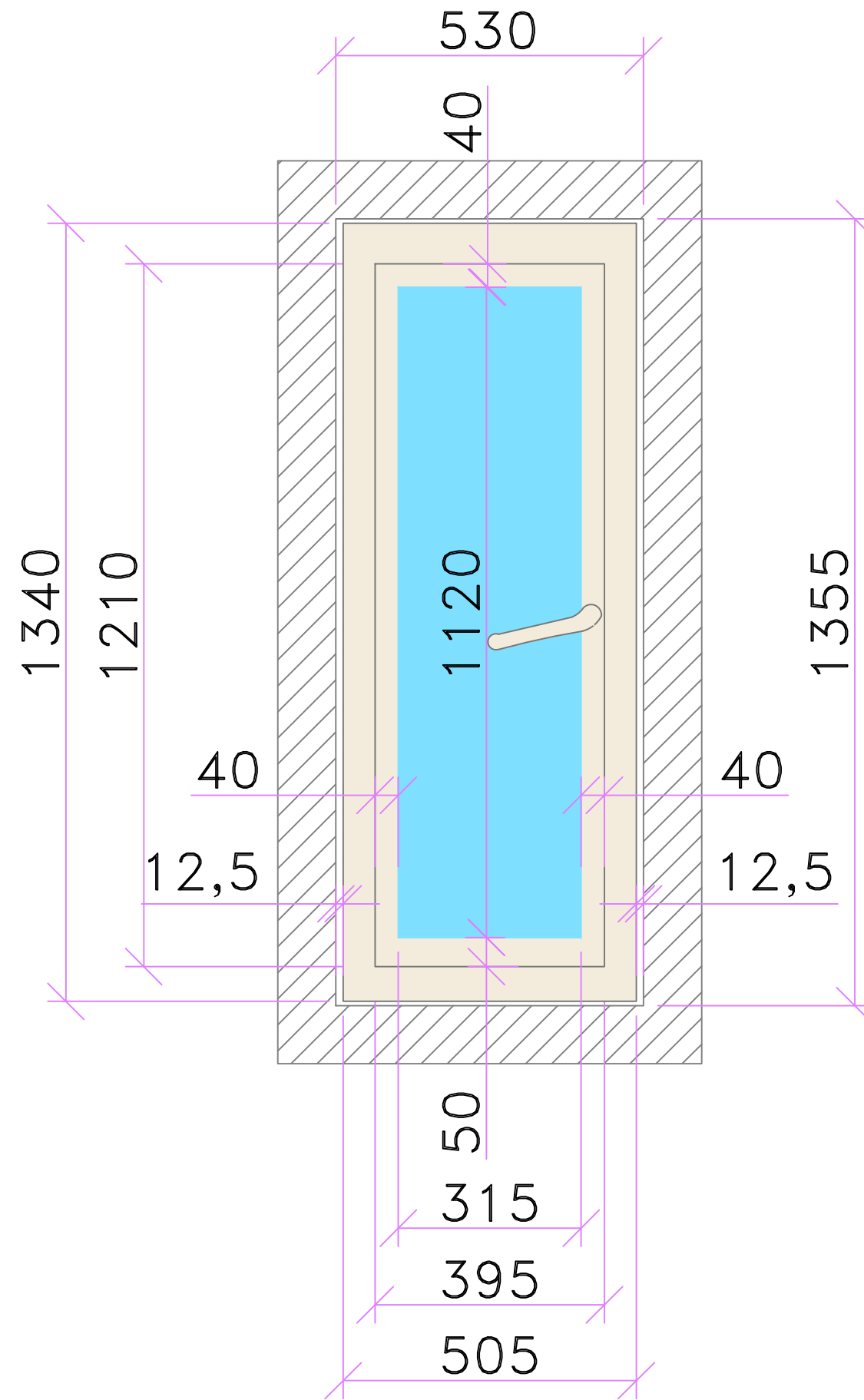

EIL-CPE
Résidence SP Perralière Villeurbanne



N°affaire: A20862
Phase: DCE
Indice: 1
Date: 10/09/2014
Ech - Format: 1/10 - A3
Dessinateur: ABENT

Fe-2
PIGNONS

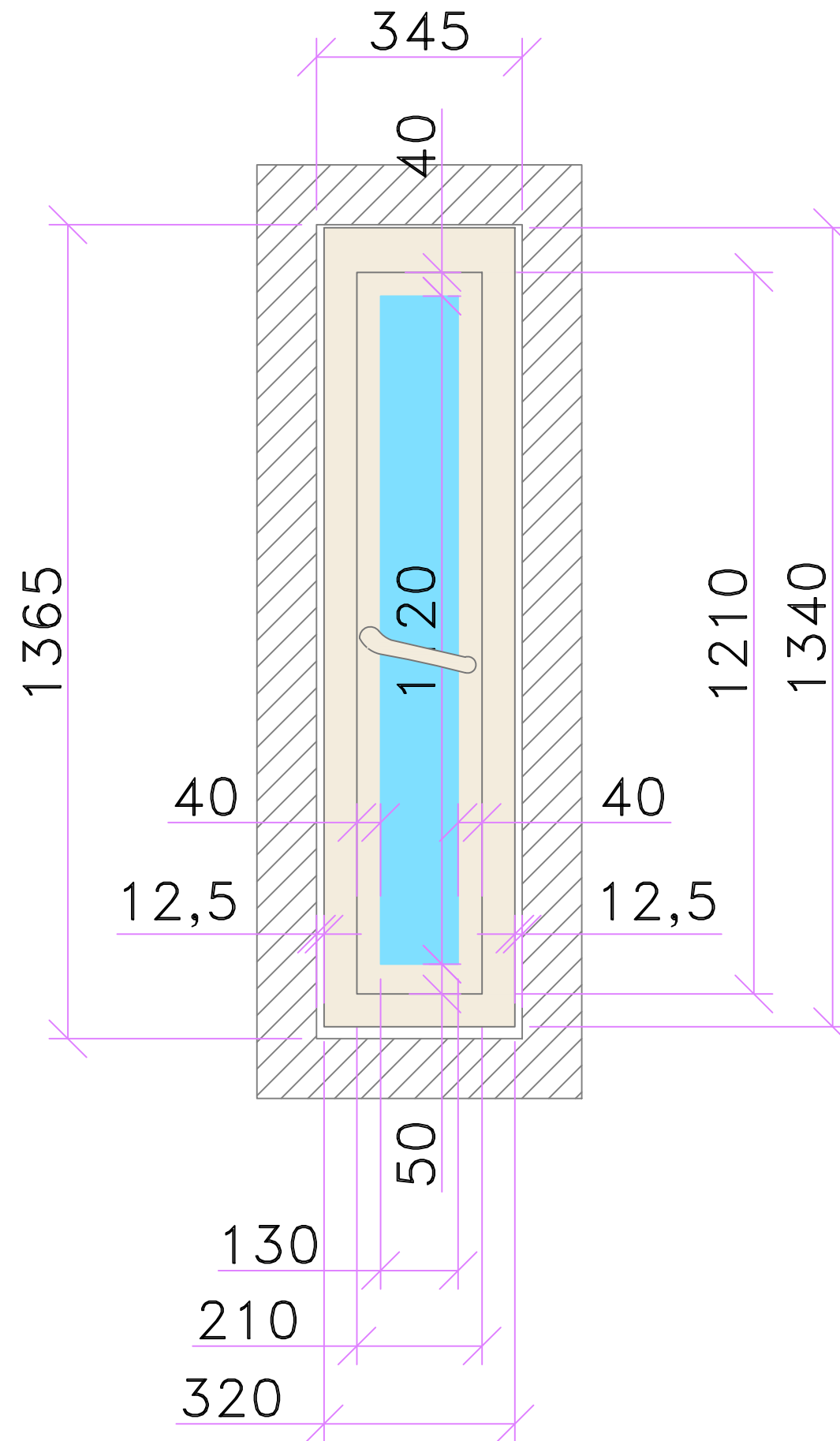

EIL-CPE
Résidence SP Perralière Villeurbanne



N°affaire: A20862
Phase: DCE
Indice: 1
Date: 10/09/2014
Ech - Format: 1/10 - A3
Dessinateur: ABENT

Fe-3
PIGNONS

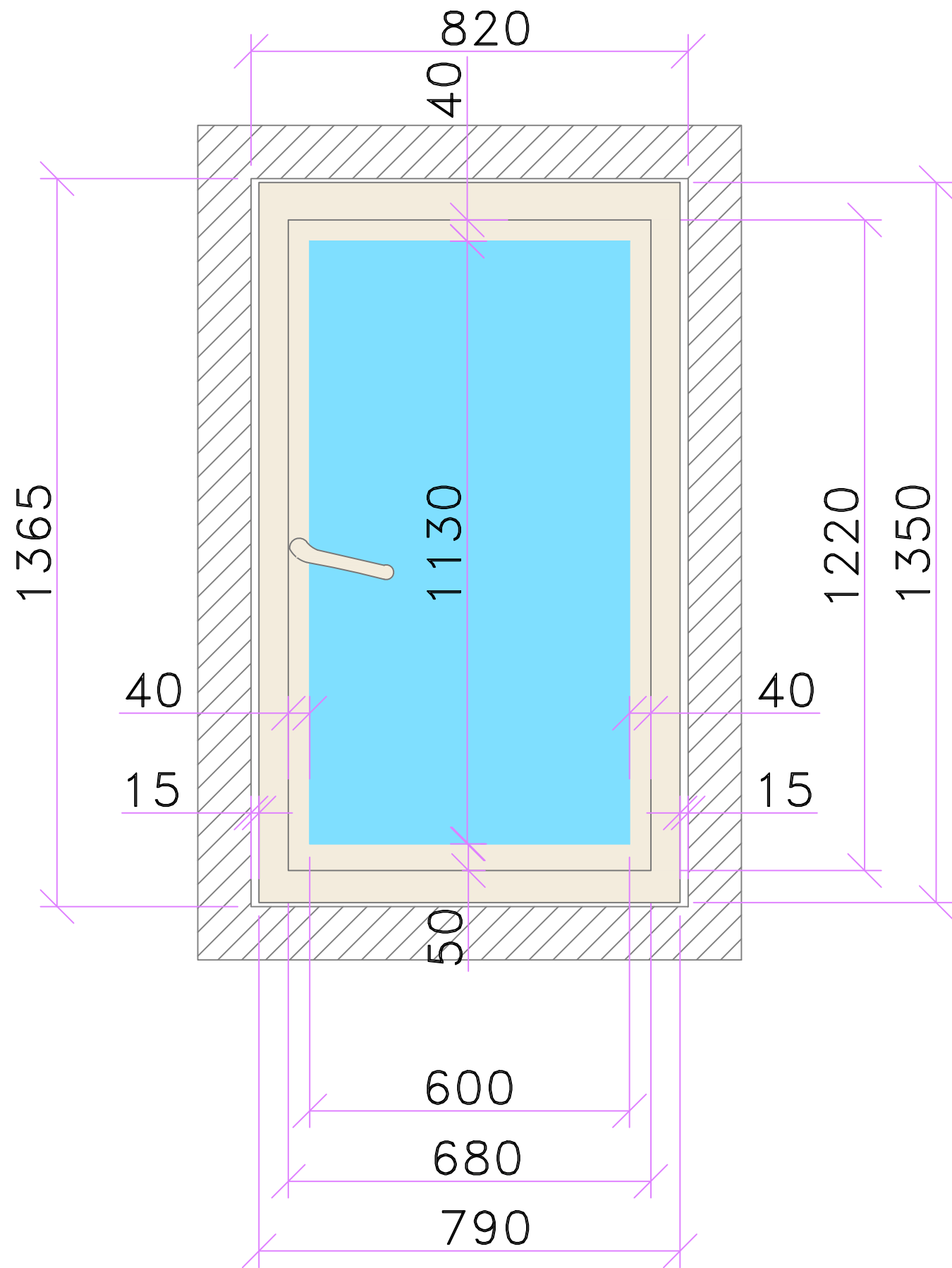

EIL-CPE
 Résidence SP Perralière Villeurbanne



N°affaire: A20862
 Phase: DCE
 Indice: 1
 Date: 10/09/2014
 Ech - Format: 1/10 - A3
 Dessinateur: ABENT

Fe-4
 PIGNONS

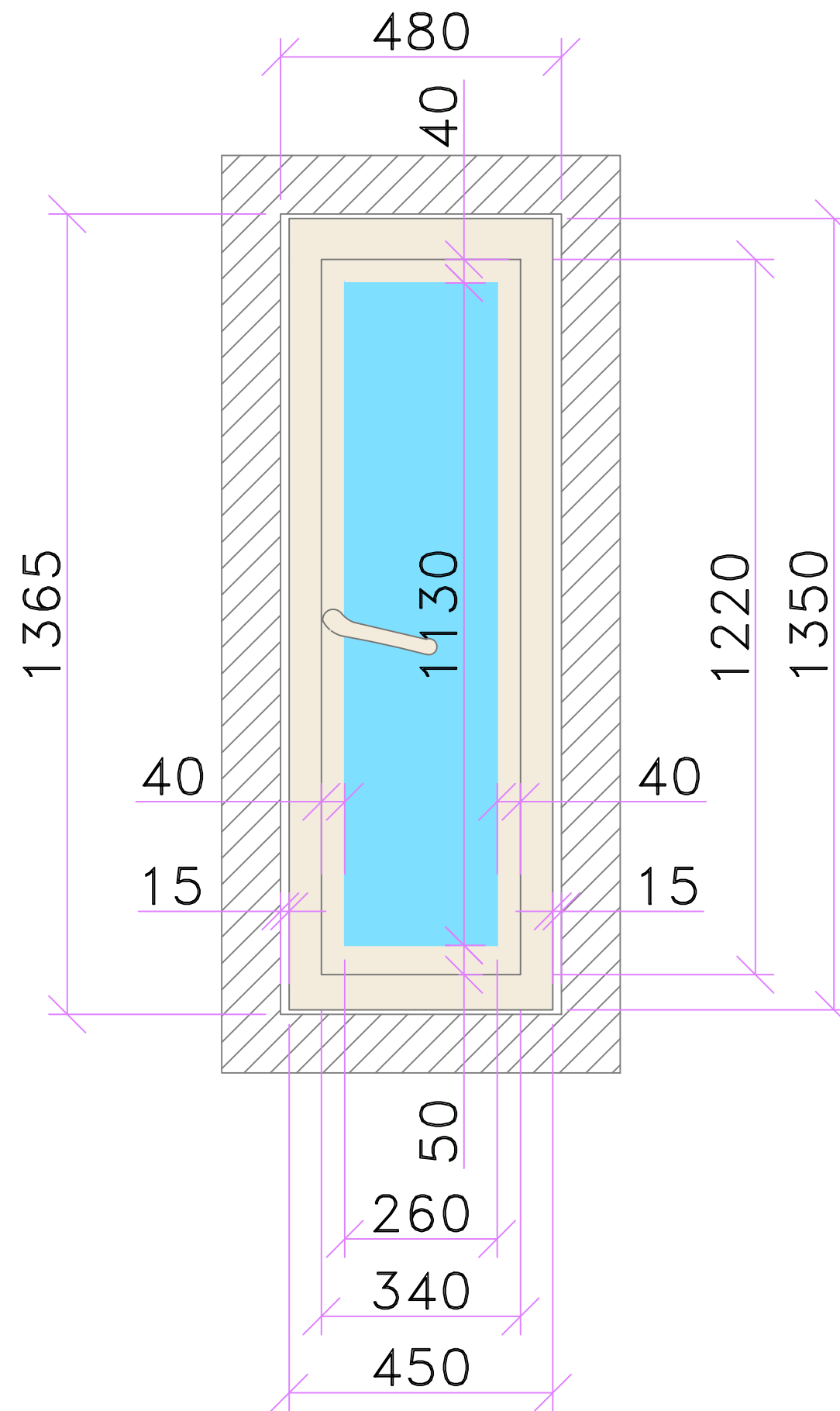

EIL-CPE
Résidence SP Perralière Villeurbanne



N°affaire: A20862
Phase: DCE
Indice: 1
Date: 10/09/2014
Ech - Format: 1/10 - A3
Dessinateur: ABENT

Fe-5
PIGNONS

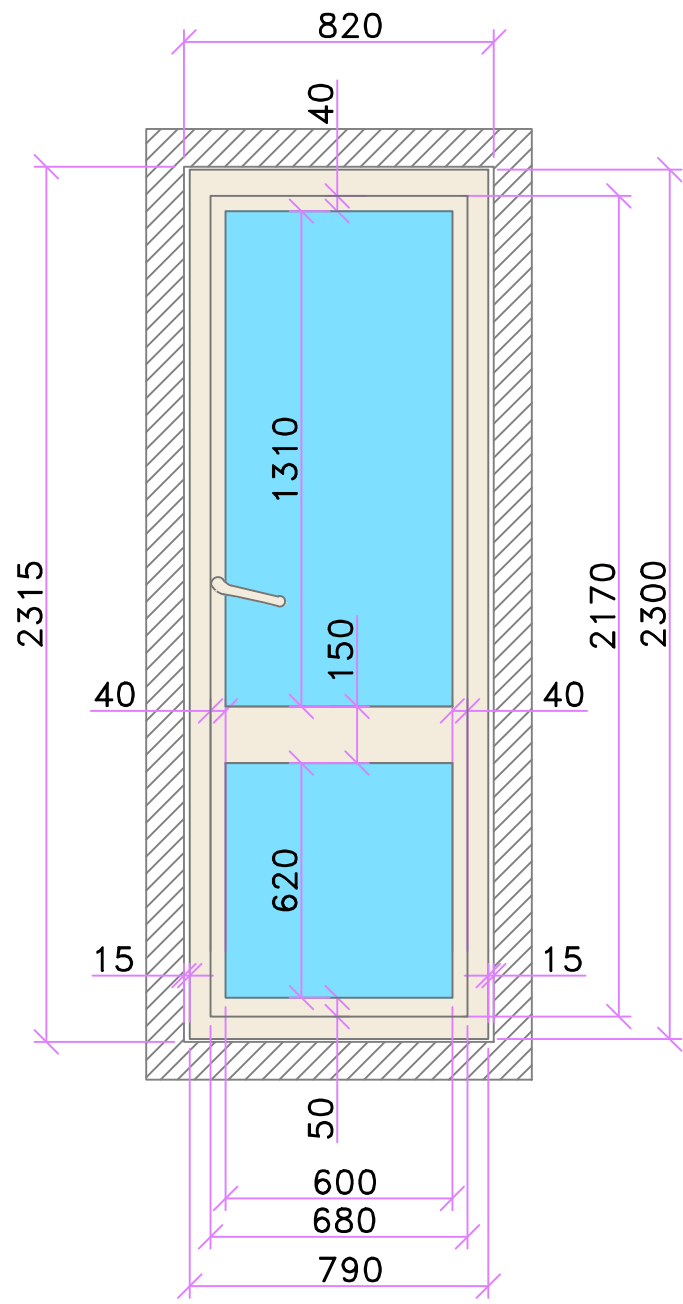

EIL-CPE
 Résidence SP Perralière Villeurbanne



N°affaire: A20862
 Phase: DCE
 Indice: 1
 Date: 10/09/2014
 Ech - Format: 1/20 - A3
 Dessinateur: ABENT

Fe-6
 PIGNONS

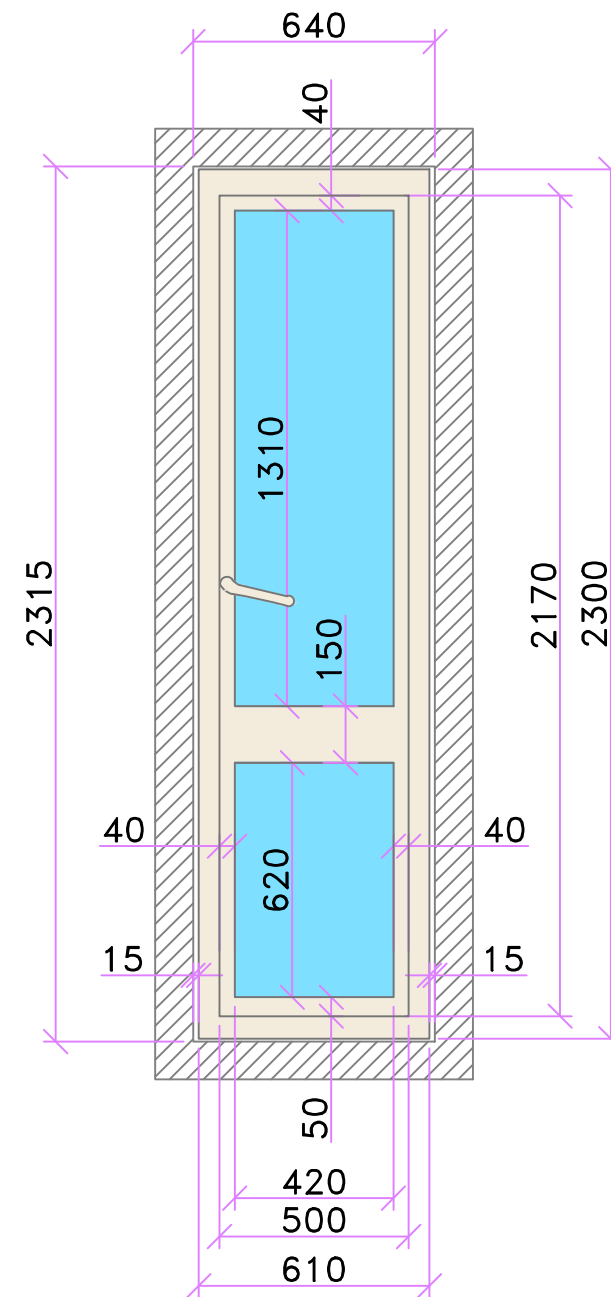

EIL-CPE
 Résidence SP Perralière Villeurbanne



N°affaire: A20862
 Phase: DCE
 Indice: 1
 Date: 10/09/2014
 Ech - Format: 1/20 - A3
 Dessinateur: ABENT

Fe-7
 PIGNONS

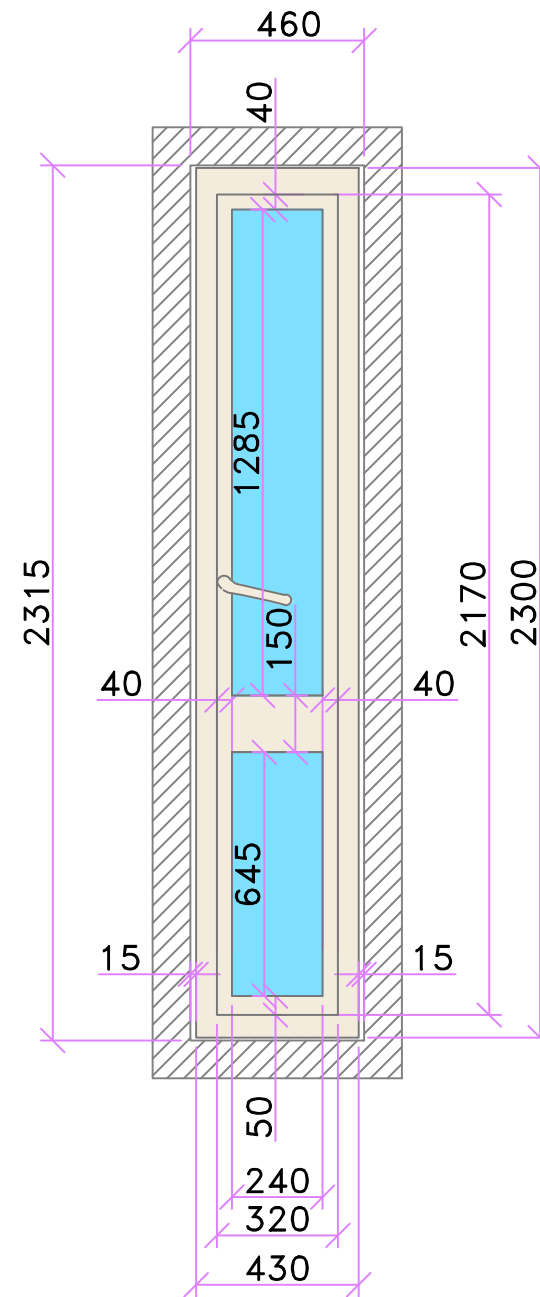

EIL-CPE
 Résidence SP Perralière Villeurbanne



N°affaire: A20862
 Phase: DCE
 Indice: 1
 Date: 10/09/2014
 Ech - Format: 1/20 - A3
 Dessinateur: ABENT

Fe-8
 PIGNONS

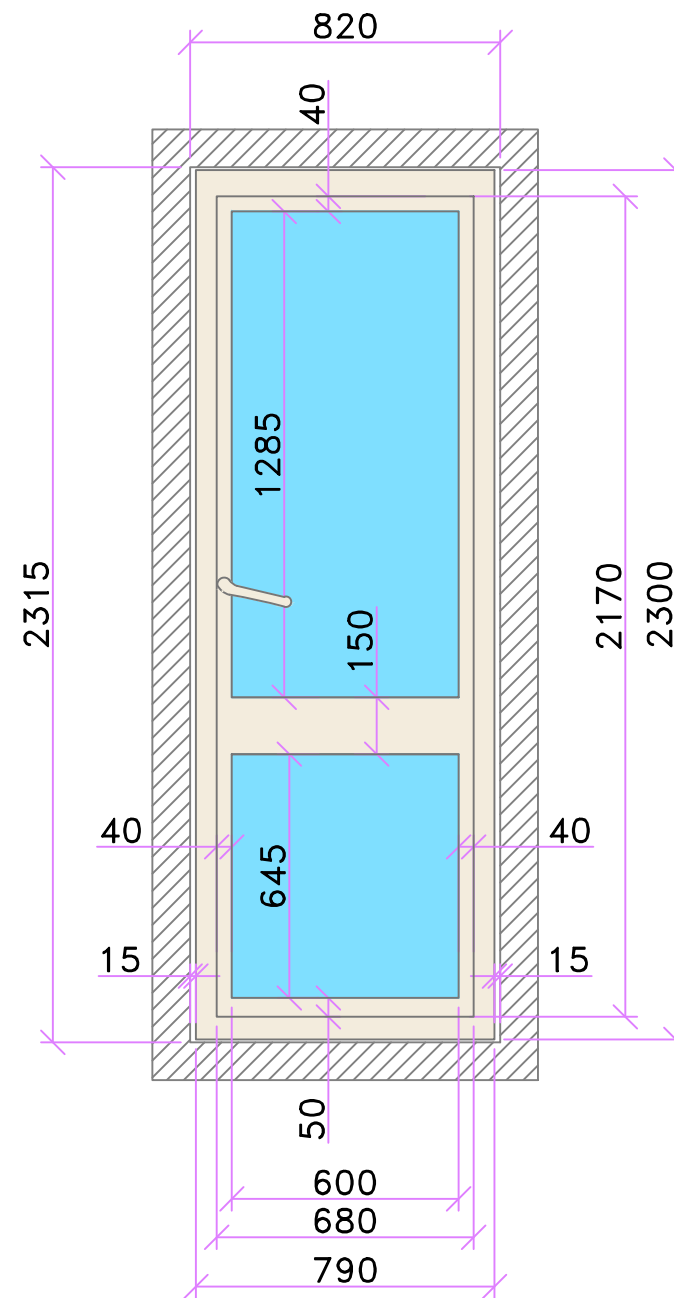

EIL-CPE
 Résidence SP Perralière Villeurbanne



N°affaire: A20862
 Phase: DCE
 Indice: 1
 Date: 10/09/2014
 Ech - Format: 1/20 - A3
 Dessinateur: ABENT

Fe-9
 PIGNONS

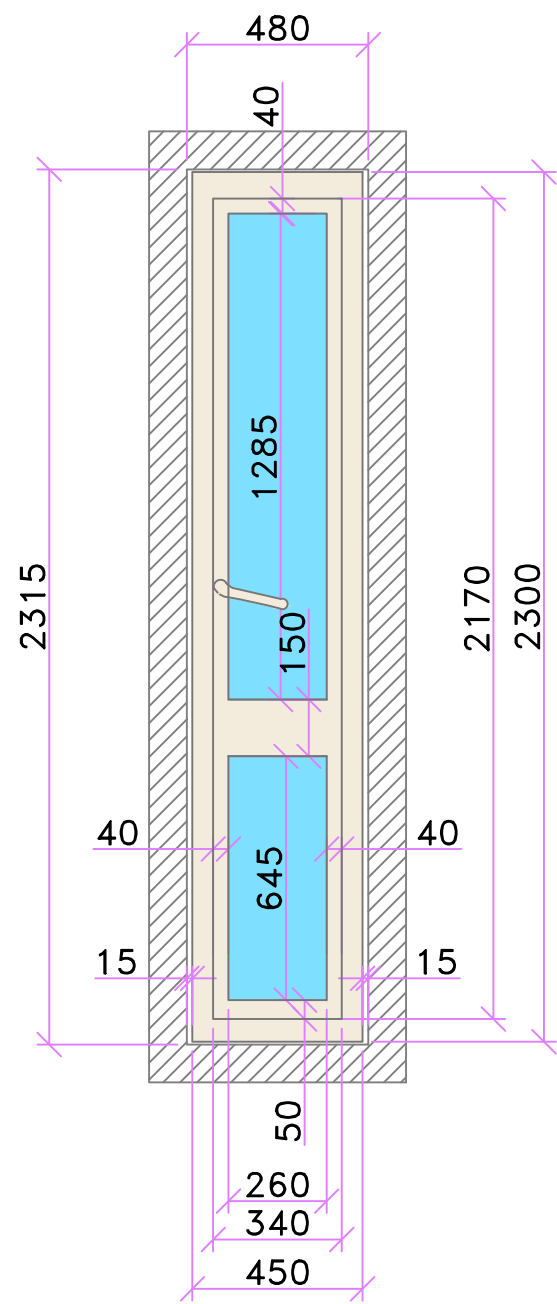

EIL-CPE
 Résidence SP Perralière Villeurbanne



N°affaire: A20862
 Phase: DCE
 Indice: 1
 Date: 10/09/2014
 Ech - Format: 1/20 - A3
 Dessinateur: ABENT

Fe-10
 PIGNONS